

MJS
88-00 fee
Plat 40-00

011691

FILED FOR RECORD
SCOTLAND COUNTY
S.C.
Nov 27 4 21 PM '95
SALLIE C. SMITH
CLERK OF COURT

**DECLARATION
OF
COVENANTS CONDITIONS AND RESTRICTIONS**

THE SUMMIT



DRAWN BY AND MAIL TO:

Kennedy, Covington, Lobdell & Hickman, L.L.P.
Suite 4200
100 North Tryon Street
Charlotte, NC 28202-4006

TABLE OF CONTENTS

	Page
ARTICLE 1	2
DEFINITIONS	2
<u>Section 1.1.</u> "Additional Property"	2
<u>Section 1.2.</u> "Amenity Area"	2
<u>Section 1.3.</u> "Approved Builder"	3
<u>Section 1.4.</u> "Articles of Incorporation"	3
<u>Section 1.5.</u> "Association"	3
<u>Section 1.6.</u> "Board of Directors"	3
<u>Section 1.7.</u> "Boatslip Lots"	3
<u>Section 1.8.</u> "Boatslip" or "Boatslips"	3
<u>Section 1.10.</u> "Bylaws"	3
<u>Section 1.11.</u> "Clubhouse"	4
<u>Section 1.12.</u> "Common Area" or "Common Areas"	4
<u>Section 1.13.</u> "Declarant"	4
<u>Section 1.14.</u> "Development"	4
<u>Section 1.15.</u> "Entrance Monument"	4
<u>Section 1.16.</u> "Lot" or "Lots"	4
<u>Section 1.17.</u> "Map"	4
<u>Section 1.18.</u> "Member"	4
<u>Section 1.19.</u> "Mortgage"	4
<u>Section 1.20.</u> "Mortgagee"	4
<u>Section 1.21.</u> "Non-Boatslip Lots"	4
<u>Section 1.22.</u> "Owner"	5
<u>Section 1.23.</u> "Parking Area"	5
<u>Section 1.24.</u> "Pier" or "Piers"	5
<u>Section 1.25.</u> "Pool"	5
<u>Section 1.26.</u> "Private Road Easement"	5
<u>Section 1.27.</u> "Private Road"	6
<u>Section 1.28.</u> "Property"	6
<u>Section 1.29.</u> "Public Roads"	6
<u>Section 1.30.</u> "Street Lights"	6
<u>Section 1.31.</u> "Subdivision"	6
<u>Section 1.32.</u> "Tennis Court"	6
ARTICLE 2	7
PROPERTY SUBJECT TO THIS DECLARATION AND WITHIN THE JURISDICTION OF THE ASSOCIATION	7
<u>Section 2.1.</u> <u>Property</u>	7
<u>Section 2.2.</u> <u>Additions to the Property</u>	7
ARTICLE 3	7
PROPERTY RIGHTS	7
<u>Section 3.1.</u> <u>Ownership of Common Areas</u>	7
<u>Section 3.2.</u> <u>Owners' Rights to Use and Enjoy Common Areas and the Private Road</u>	8

FILED FOR RECORDED
 IN THE CLERK OF COURT
 S.C.
 NOV 27 4 21 PM '95
 SALLIE O. SMITH
 CLERK OF COURT

	<u>Section 3.3. Delegation of Use</u>	9
ARTICLE 4	9
	THE ASSOCIATION	9
	<u>Section 4.1. Membership</u>	9
	<u>Section 4.2. Classes of Lots and Voting Rights</u>	9
	<u>Section 4.3. Relinquishment of Control</u>	9
	<u>Section 4.4. Availability of Documents</u>	10
	<u>Section 4.5. Management Contracts</u>	10
	<u>Section 4.6. Maintenance</u>	10
	<u>Section 4.7. Reserve Fund</u>	12
	<u>Section 4.8. Piers and Boatslips</u>	12
	<u>Section 4.9. Parking Area</u>	15
	<u>Section 4.10. Pool</u>	15
	<u>Section 4.11. Clubhouse</u>	15
	<u>Section 4.12. Amenity Area</u>	15
	<u>Section 4.13. Tennis Court</u>	15
	<u>Section 4.14. Boat Storage Area</u>	15
	<u>Section 4.15. Private Road</u>	15
ARTICLE 5	17
	COVENANT FOR ANNUAL AND SPECIAL ASSESSMENTS	17
	<u>Section 5.1. Creation of the Lien and Personal Obligation for Annual, Supplemental Annual, Special and Special Individual Assessments</u>	17
	<u>Section 5.2. Purpose of Annual Assessments</u>	17
	<u>Section 5.3. Payment of Annual Assessments; Due Dates</u>	18
	<u>Section 5.4. Maximum Annual Assessment</u>	19
	<u>Section 5.5. Special Assessments for Capital Improvements</u>	20
	<u>Section 5.6. Special Individual Assessments</u>	20
	<u>Section 5.7. Assessment Rate</u>	21
ARTICLE 6	21
	COVENANT FOR BOATSLIP AND SPECIAL BOATSLIP ASSESSMENTS	21
	<u>Section 6.1. Creation of the Lien and Personal Obligation for Boatslip, Supplemental Boatslip and Special Boatslip Assessments</u>	21
	<u>Section 6.2. Purpose of Boatslip Assessments</u>	22
	<u>Section 6.3. Payment of Boatslip Assessments; Due Dates</u>	22
	<u>Section 6.4. Maximum Boatslip Assessment</u>	23
	<u>Section 6.5. Special Assessments for Boatslip Improvements</u>	24
	<u>Section 6.6. Assessment Rate</u>	24
ARTICLE 7	24
	GENERAL ASSESSMENT PROVISIONS	24
	<u>Section 7.1. Certificate Regarding Assessments</u>	24
	<u>Section 7.2. Effect of Nonpayment of Assessments; Remedies of the Association</u>	25

	<u>Section 7.3. Subordination of the Lien to Mortgages</u>	25
ARTICLE 8		25
	RESTRICTIONS	25
	<u>Section 8.1. Land Use, Building Type and Residential Restrictions</u>	25
	<u>Section 8.2. Dwelling Size</u>	26
	<u>Section 8.3. Building Construction and Quality</u>	26
	<u>Section 8.4. Temporary Structures; Structure Materials</u>	27
	<u>Section 8.5. Building Setback Lines</u>	27
	<u>Section 8.6. Minor Setback Violations</u>	28
	<u>Section 8.7. Combination or Subdivision of Lots</u>	28
	<u>Section 8.8. Utility Easements</u>	29
	<u>Section 8.9. Entrance Monument Easement</u>	29
	<u>Section 8.10. Fences and Walls</u>	30
	<u>Section 8.11. Signs</u>	30
	<u>Section 8.12. Antennas; Satellite Dishes or Discs</u>	30
	<u>Section 8.13. Lot Maintenance; Trash Disposal</u>	30
	<u>Section 8.14. Off-Street Parking; Off-Water Boat Storage</u>	31
	<u>Section 8.15. Sewage Disposal</u>	31
	<u>Section 8.16. Nuisances</u>	31
	<u>Section 8.17. Diligent Construction</u>	32
	<u>Section 8.18. Community Water System; No Private Individual Wells</u>	32
	<u>Section 8.19. Removal of Trees and Other Vegetation</u>	33
	<u>Section 8.20. Marine Toilets</u>	34
	<u>Section 8.21. Docks, Piers and Boat Houses</u>	34
ARTICLE 9		35
	INSURANCE	35
	<u>Section 9.1. Board of Directors</u>	35
	<u>Section 9.2. Premium Expense</u>	37
	<u>Section 9.3. Special Endorsements</u>	37
	<u>Section 9.4. General Guidelines</u>	37
	<u>Section 9.5. Owner's Personal Property</u>	37
ARTICLE 10		38
	RIGHTS OF MORTGAGEES	38
	<u>Section 10.1. Approval of Mortgagees</u>	38
	<u>Section 10.2. Additional Rights</u>	38
	<u>Section 10.3. Books and Records</u>	39
	<u>Section 10.4. Payment of Taxes and Insurance Premiums</u>	39
ARTICLE 11		40
	CONDEMNATION	40
	<u>Section 11.1. Partial Taking Without Direct Effect on Lots</u>	40
	<u>Section 11.2. Partial or Total Taking Directly Affecting Lots</u>	40

Section 11.3. Notice to Mortgagees 41

ARTICLE 12 41

GENERAL PROVISIONS 41

Section 12.1. Enforcement 41

Section 12.2. Severability 42

Section 12.3. Amendment 42

Section 12.4. Term 43

Section 12.5. FHA/VA Approval 43

EXHIBIT "A" ARTICLES OF INCORPORATION

EXHIBIT "B" BYLAWS

EXHIBIT "C" PIERS AND BOATSLIPS

EXHIBIT "D" EROSION CONTROL PRACTICES

EXHIBIT "E" STANDARD COMMUNITY MAILBOXES



FILED FOR RECORD
 OCONEE COUNTY
 S.C.
 Nov 27 4 21 PM '95
 SALLIE O. SMITH
 CLERK OF COURT

DECLARATION
OF COVENANTS, CONDITIONS AND RESTRICTIONS

THE SUMMIT

THIS DECLARATION OF COVENANTS, CONDITIONS AND RESTRICTIONS ("Declaration") is made this _____ day of _____, 19__ by CRESCENT RESOURCES, INC., a South Carolina corporation, hereinafter referred to as "Declarant". All capitalized terms used herein shall have the meanings set forth in Article 1 or elsewhere in this Declaration.

STATEMENT OF PURPOSE

Declarant is the developer and owner of certain property located in Oconee County, South Carolina, which is more particularly described on that certain map recorded in Map Book A374, Page 9-12 in the Office of the Clerk of Court for Oconee County. Declarant desires to provide for the creation on the property shown on that map a residential community of single-family residences to be named THE SUMMIT (the "Development").

Declarant desires to insure the attractiveness of the Development, to prevent any future impairment thereof, to prevent nuisances and enhance the value and amenities of all properties within the Development. Furthermore, Declarant desires to provide for the maintenance and upkeep of certain Common Areas within the Development for the common use and benefit of all Property Owners, including, but not limited to, Street Lights (to be leased from Duke Power Company), Amenity Area, Parking Area, Clubhouse, Pool, Tennis Court, Entrance Monument, Boat Storage Area and Public Roads (prior to acceptance by governmental authorities for public maintenance). As part of such Common Areas, Declarant desires to construct and provide for the maintenance and upkeep of a lighted Entrance Monument to be located at the entrance to the Development, which Entrance Monument will be for the common use and benefit of all Owners. Declarant further desires to construct and provide as part of such Common Areas Piers containing Boatslips over the waters of Lake Keowee, which Piers with Boatslips will be for the common use and benefit of certain, but not all Owners.

Declarant desires to provide for a system whereby all Owners will pay for the maintenance and upkeep of the Common Areas; provided, however, that maintenance and upkeep of the Piers and Boatslips will be paid for only by Owners in the Development who are entitled to the use of a Boatslip and Pier. All Owners in the Development will pay the cost associated with leasing the Street Lights from Duke Power Company and the cost of maintenance and upkeep of the Amenity Area, Pool, Tennis Court, Clubhouse, Parking Area, Entrance Monument, Boat Storage Area and Public Roads (prior to their acceptance for public maintenance) and such other Common Areas as such Owners are entitled to use and enjoy.

To these ends, Declarant desires to subject the real property described herein to the covenants, conditions, restrictions, easements, charges and liens hereinafter set forth, each and all of which is and are for the benefit of said property and each Owner thereof.

Declarant further desires to create an organization to which will be delegated and assigned the powers of owning, maintaining and administering the Common Areas, administering and enforcing the covenants and restrictions contained herein, and collecting and disbursing the assessments and charges hereinafter created, in order to efficiently preserve, protect and enhance the values and amenities in the Development, to ensure the residents' enjoyment of the specific rights, privileges and easements in the Common Areas, and to provide for the maintenance and upkeep of the Common Areas and amenities.

To that end the Declarant has or will cause to be incorporated under South Carolina law, pursuant to the Articles of Incorporation attached hereto as Exhibit "A" and incorporated herein by reference, THE SUMMIT OWNERS' ASSOCIATION, INC., as a non-profit corporation for the purpose of exercising and performing the aforesaid functions, said corporation to be governed by the Bylaws attached hereto as Exhibit "B" and incorporated herein by reference.

NOW, THEREFORE, Declarant, by this Declaration, does declare that all of the property described herein is and shall be held, transferred, sold, conveyed and occupied subject to the covenants, conditions, restrictions, easements, charges and liens set forth in this Declaration, which shall run with the real property described herein and be binding on all parties owning any right, title or interest in said real property or any part thereof, their heirs, successors and assigns, and shall inure to the benefit of each Owner thereof.

ARTICLE 1

DEFINITIONS

Section 1.1. "Additional Property" shall mean and refer to additional real estate contiguous or adjacent to the Property, including any portion of the Common Areas which are conveyed back to Declarant by the Association, and any property located within two thousand feet of the Property shown on the Map, all or a portion of which may be made subject to the terms of this Declaration in accordance with the provisions of Section 2.2 of this Declaration.

Section 1.2. "Amenity Area" shall mean and refer to the parcel of land labeled "Amenity Area" on the Map, together with the Clubhouse, Pool, Tennis Court, Pier, Boatslips and Parking Area

FILED FOR RECORD
OCCONEE COUNTY
S.C.
4 22 PM '95
JULIE C. SMITH
CLERK OF COURT

which shall be constructed thereon and made subject to the terms of this Declaration in accordance with the provisions of Article 2 and Article 3, Section 1 of this Declaration for the common use and enjoyment of all Owners, except the Pier and Boatslips which will be for the sole use and enjoyment of the Boatslip Lot Owners.

Section 1.3. "Approved Builder" shall mean and refer to one or more persons or companies, in the business of building and selling homes to individuals, selected by Declarant to buy Lots and construct homes for sale in the Subdivision.

Section 1.4. "Articles of Incorporation" shall mean and refer to the Articles of Incorporation for the Association attached as Exhibit "A" hereto, and incorporated herein by reference.

Section 1.5. "Association" shall mean and refer to THE SUMMIT OWNERS' ASSOCIATION, INC., a South Carolina non-profit corporation, its successors and assigns.

Section 1.6. "Board of Directors" shall mean and refer to the Board of Directors of the Association, which shall be elected and shall serve pursuant to the Bylaws.

Section 1.7. "Boatslip Lots" shall initially mean and refer to Lots 1-22, 36, 52, 53, 58-60, as shown on the Map, which have, as an appurtenance to the Lot, the right to use an assigned Boatslip acquired by deed from Declarant, and shall mean and refer to any other Lot which has had a Boatslip transferred to it as an appurtenance to such Lot by other conveyance, as more particularly set forth in Section 4.6 and Section 4.8 of this Declaration.

Section 1.8. "Boatslip" or "Boatslips" shall mean and refer to the boatslips over the waters of Lake Keowee, which Boatslips are designated as Boatslips 1 through 28 on Exhibit "C", attached hereto and incorporated herein by reference, together with any additional Boatslips which Declarant may cause to be constructed in accordance with the terms of Section 2.2 of this Declaration, and which Boatslips are more particularly addressed in Article 4 and Article 6 of this Declaration.

Section 1.9. "Boat Storage Area" shall mean and refer to the Common Area labelled on the Map as "Boat Storage Area", together with any additional Boat Storage Areas which Declarant may cause to be constructed in accordance with the terms of Section 2.2 of this Declaration, and which Boat Storage Area is more particularly addressed in Article 4 of this Declaration.

Section 1.10. "Bylaws" shall mean and refer to the Bylaws for the Association, attached as Exhibit "B" hereto and incorporated herein by reference.



SALLIE G. CLERK OF
Nov 27 4 2
265104.4
FILED FOR
S.C.
S.C. COMMERCE

Section 1.11. "Clubhouse" shall mean and refer to that building which shall be constructed upon and within the Amenity Area, made subject to the terms of this Declaration in accordance with the provisions of Article 3, Section 1 of this Declaration, for the common use and enjoyment of all of the Owners, their families, guests and invitees as more particularly addressed in Section 4.11 of this Declaration.

Section 1.12. "Common Area" or "Common Areas" shall mean and refer to the Amenity Area, Parking Area, Clubhouse, Pool, Tennis Court, Piers, Boat Storage Area, Boatslips, Entrance Monument, Street Lights (to be leased from Duke Power Company) and Public Roads (prior to their acceptance for maintenance by the Oconee County Public Works Department or other governmental entity) and medians located thereon, collectively, and any other property shown and designated on the Map as "COS" or "Common Open Space." The Common Areas shall be owned by the Association (except as otherwise provided herein) for the common use, benefit and enjoyment of the Owners; provided, however, that only the Owners of Boatslip Lots shall be entitled to the use, benefit and enjoyment of the specified Boatslips and Piers, as designated in this Declaration or any one or more Supplemental Declaration. The Declarant reserves the right, but not the obligation, to provide additional Common Areas within the Subdivision.

Section 1.13. "Declarant" shall mean and refer to Crescent Resources, Inc., and such of its successors and assigns to whom the rights of Declarant hereunder are transferred by written instrument recorded in the office of the Clerk of Court for Oconee County.

Section 1.14. "Development" shall mean and refer to The Summit, a single-family residential development proposed to be developed on the Property by Declarant.

Section 1.15. "Entrance Monument" or "Entrance Monuments" shall mean and refer to the easement areas (designated as the "Entrance Monument Easement" on the Map) reserved and granted by Declarant in Section 8.9 of this Declaration, over a portion of Common Area as shown on the Map, and the stone monuments and entrance signs located on such Common Area together with lighting, irrigation system, landscaping and other improvements to be constructed on such easement area, to be used as an entryway for the Subdivision, and for the purposes set forth in Section 8.9.

Section 1.16. "Lot" or "Lots" shall mean and refer to the separately numbered parcels depicted on the Map, which Lots do not include the Amenity Area, Boat Storage Area, and other Common Areas as described in this Declaration.

Section 1.17. "Map" shall mean and refer to (i) the map of The Summit Subdivision recorded in Map Book A374, Page 9-12, in the Office of the Clerk of Court for Oconee County, South

FILED FOR
OCCONEE
S.C.
NOV 27 4 22
SALLIE O. SMITH
CLERK OF COURT

Carolina, (ii) any maps of Additional Property, and (iii) any revisions of such map or maps recorded in such Office.

Section 1.18. "Member" shall mean and refer to every person or entity who holds membership in the Association.

Section 1.19. "Mortgage" shall mean any mortgage or deed of trust constituting a first lien on a Lot.

Section 1.20. "Mortgagee" shall mean the owner and holder of a Mortgage at the time such term is being applied.

Section 1.21. "Non-Boatslip Lots" shall mean and refer to those Lots in the Development which do not have, as an appurtenance thereto, the right to use a Boatslip.

Section 1.22. "Owner" shall mean and refer to the record owner, whether one or more persons or entities, of fee simple title to any Lot within the Development, including the Declarant if it owns any Lot, and including any Approved Builder if it owns a Lot, but excluding those having such interest merely as security for the performance of an obligation.

Section 1.23. "Parking Area" shall mean and refer to the parking lot which will be constructed upon and over the Amenity Area for the common use, benefit and enjoyment of all Owners, to provide parking for such Owners, their families, guests and invitees in connection with their use of the Amenity Area. The Parking Area is more particularly addressed in Section 4.9 of this Declaration.

Section 1.24. "Pier" or "Piers" shall mean and refer to the pier or piers, containing the Boatslips, which will be constructed over the waters of Lake Keowee, including the Pier shown on Exhibit "C" attached hereto and incorporated herein by reference, together with any additional Piers which Declarant may cause to be constructed in accordance with the terms of Section 2.2 of this Declaration, and which Piers are more particularly addressed in Section 4.6 and Section 4.8 of this Declaration.

Section 1.25. "Pool" shall mean and refer to that swimming pool which will be constructed by Declarant within the Amenity Area and made subject to this Declaration in accordance with the provisions of Section 3.1 of this Declaration for the common use, benefit and enjoyment of all Owners, their families, guests and invitees as more particularly addressed in Section 4.10 of this Declaration.

Section 1.26. "Private Road Easement" shall mean and refer to the non-exclusive, perpetual easement fifteen feet (15') in width in the location more specifically identified on the Map as "Private Road Easement" for access, ingress and egress from Summit Drive and

across Lots 46 and 48, which has been granted by the Declarant to the Owners of Lots 46 and 47 in the Subdivision (the "Private Road Lots"), their heirs, successors and assigns. The Private Road Easement is also reserved unto the Declarant, its successors and assigns, and unto the Association, for access, ingress and egress to the Private Road Lots and for the installation of the Private Road, and the installation and maintenance of the utilities and drainage facilities.

Section 1.27. "Private Road" shall mean and refer to that certain private road located within the Private Road Easement which will provide access to each of the Private Road Lots upon completion, and will be dedicated to the Owners of the Private Roads Lots, all to be maintained by the Owners of the Private Road Lots as addressed in Section 4.15 of this Declaration.

Section 1.28. "Property" shall mean and refer to the property shown on the Map, including the Lots and Common Areas, Public Roads (prior to such roads being accepted for public maintenance by the Oconee County Public Works Department or other governmental entity) and the Private Road, together with any leasehold interest or easement which the Association has or may hereafter acquire in any property adjacent to the Development (including, but not limited to, any leases of any submerged land lying within the bed of Lake Keowee).

Section 1.29. "Public Roads" shall mean and refer to all road or roads and cul-de-sacs in the Subdivision dedicated to the public as shown on the Map, all to be maintained by the Association (subject to potential reimbursement from Declarant as set forth in Section 4.6 of this Declaration) until accepted for dedication and public maintenance by the Oconee County Public Works Department or other governmental entity.

Section 1.30. "Street Lights" shall mean and refer to those certain street lights, which are to be maintained by Duke Power Company and leased by the Association, which may be constructed upon and over the rights-of-way of the Public Roads, Boat Storage Area and Amenity Area.

Section 1.31. "Subdivision" shall mean and refer to The Summit Subdivision, as the same is shown on the Map.

Section 1.32. "Tennis Court" shall mean and refer to that tennis court to be constructed by Declarant within and upon the Amenity Area for the common use and enjoyment of all Owners, their families, guests and invitees, as more particularly addressed in Section 4.13.

FILED FOR RECORD
OCONEE COUNTY
S.O.
NOV 27 4 22 PM '95
SALLIE O. SMITH
CLERK OF COURT

ARTICLE 2

PROPERTY SUBJECT TO THIS DECLARATION AND WITHIN THE JURISDICTION OF THE ASSOCIATION

Section 2.1. Property. The real property which is and shall be held, transferred, sold, conveyed and occupied subject to this Declaration, and which is and shall be within the jurisdiction of the Association, is located in Oconee County, South Carolina, and is the Property as defined above and as more particularly described and shown on the Map.

Section 2.2. Additions to the Property.

(a) Declarant may cause Additional Property to be made subject to the terms and scheme of this Declaration by filing one or more Supplemental Declarations in the Office of the Clerk of Court for Oconee County, containing a description of the Additional Property and a statement by the Declarant of its intent to extend the operation and effect of this Declaration to the Additional Property. Declarant may also cause additional Common Areas and Piers and Boatslips within or adjacent to any Additional Property to be constructed and made subject to the terms and scheme of this Declaration by the filing of one or more Supplemental Declarations describing the Common Areas and number of Piers and Boatslips to be added, and a statement by Declarant of its intent to extend the operation and effect of this Declaration to the additional Common Areas and Piers and Boatslips. Notwithstanding the foregoing, the covenants and restrictions established herein as applied to, or imposed upon, the Additional Property may be altered or modified by the filing of one or more Supplemental Declarations as provided in Subparagraph (b) below.

(b) Any Supplemental Declaration may contain complementary additions to the covenants and restrictions contained herein as may be necessary in the judgment of the Declarant to reflect the different character of the Additional Property. In no event, however, shall any Supplemental Declaration revoke, modify or add to the covenants and restrictions contained herein with respect to the Property, nor revoke, modify, change or add to the covenants and restrictions established by previously filed Supplemental Declarations, without meeting the requirements for Amendment set forth in Section 12.3 of this Declaration.

ARTICLE 3

PROPERTY RIGHTS

Section 3.1. Ownership of Common Areas. Declarant shall convey to the Association the Common Areas to be owned and maintained by the Association. The Declarant reserves the right to construct (i) the Clubhouse, Pool, Parking Area, Boatslips, Piers

and Tennis Court upon the Amenity Area; (ii) the Entrance Monument to be located at the entrance to the Development; (iii) the Boat Storage Area; and (iv) the Public Roads (prior to acceptance by the governmental authorities) and the Private Road, as reflected on the Map, for the use and enjoyment of the Owners who are entitled to the use of such Common Areas as provided in this Declaration. Notwithstanding the recordation of any Map or any other action by Declarant or the Association, all Common Areas (except for the Public Roads upon acceptance by the Oconee County Public Works Department for public maintenance) and the Private Road shall remain private property and shall not be considered as dedicated to the use and enjoyment of the public. Furthermore, the Declarant has created the Private Road Easement over and upon a portion of Lots 46 and 48 for the purpose of providing access for the Private Road Lots, which Private Road Easement will be for the sole benefit and use of the Owners of the Private Road Lots, as provided in Section 4.15 of this Declaration, and is not, and shall not be Common Area.

Section 3.2. Owners' Rights to Use and Enjoy Common Areas and the Private Road. Each Owner shall have the non-exclusive easement and right to use and enjoy the Common Areas, and such right shall be appurtenant to and conveyed with title to such Owner's Lot, subject to the following:

(a) the right of the Association to promulgate and enforce reasonable regulations governing the use of the Common Areas to insure the availability of the right to use the Common Areas to the Owners and the safety of all Owners on the Common Areas;

(b) the right of the Association to suspend the voting rights of an Owner in the Association and the right of the Association to suspend the right to use certain or all of the Common Areas by an Owner for any period during which any assessment against his Lot remains unpaid, and for a period not to exceed sixty (60) days for any infraction of its published rules and regulations;

(c) the right of the Declarant or the Association to grant utility, drainage and other easements across the Common Areas;

(d) the Piers and Boatslips may be used only by those Owners specifically entitled thereto under this Declaration;

(e) the provisions of Section 4.6 and Section 4.8 below;

(f) the provisions of Article 8 of this Declaration; and

(g) the non-exclusive, perpetual Private Road Easement reserved and granted over, across and under portions of Lots 46 and 48, as more particularly described in Section 4.15 of this Declaration.

Section 3.3. Delegation of Use. Any Owner may delegate, in accordance with the Bylaws, his right of enjoyment to the Common Areas and facilities located thereon to the members of his family, his guests, invitees or tenants.

ARTICLE 4

THE ASSOCIATION

Section 4.1. Membership. Every Owner of a Lot shall be a Member of the Association. Membership shall be appurtenant to and may not be separated from ownership of any Lot, and shall be governed by the Bylaws attached as Exhibit "B" hereto.

Section 4.2. Classes of Lots and Voting Rights. The voting rights of the Membership shall be appurtenant to the ownership of Lots. There shall be two classes of Lots with respect to voting rights:

(a) Class A Lots. Class A Lots shall be all Lots except Class B Lots as defined below. Each Class A Lot shall entitle the Owner(s) of said Lot to one (1) vote. When more than one person owns an interest (other than a leasehold or security interest) in any Lot, all such persons shall be Members and the voting rights appurtenant to said Lot shall be exercised as they, among themselves, determine, but in no event shall more than one (1) vote be cast with respect to any Class A Lot.

(b) Class B Lots. Class B Lots shall be all Lots owned by Declarant which have not been conveyed to purchasers who are not affiliated with the Declarant. Each Class B Lot shall entitle the Owner of said Lot to three (3) votes for each Class B Lot owned by it.

Section 4.3. Relinquishment of Control. The Class B membership shall cease and be converted to Class A membership on the happening of one of the following events, whichever occurs earlier:

- (a) when the number of votes in the Class A membership held by Owners occupying full-time homes in the Subdivision equals the total number of votes outstanding in the Class B membership and the Declarant surrenders its right to annex any Additional Property to the Property pursuant to the Bylaws; or
- (b) upon the expiration of five (5) full years after the registration of this Declaration; or

- (c) Declarant, in its sole discretion, elects to convert the Class B Lots to Class A Lots. Any such election, to be effective, must be in writing and recorded in the Office of the Clerk of Court for Oconee County, South Carolina.

Section 4.4. Availability of Documents. The Association shall maintain current copies of the Declaration, the Bylaws and other rules concerning the Development as well as its own books, records, and financial statements available for inspection by all Owners, Mortgagees and insurers and guarantors of Mortgages that are secured by Lots. All such documents shall be available upon reasonable notice and during normal business hours. In addition, any Mortgagee may, at its own expense, have an audited statement prepared with respect to the finances of the Association.

Section 4.5. Management Contracts. The Association is authorized and empowered to engage the services of any person, firm or corporation to act as managing agent of the Association at a compensation level to be established by the Board of Directors and to perform all of the powers and duties of the Association. Provided, however, that the term of any such agreement with a managing agent shall not exceed one (1) year and shall only be renewed by agreement of the parties for successive one (1) year terms. Any such contract shall be terminable by the Association with or without cause upon ninety (90) days prior written notice to the manager without payment of a termination fee.

Section 4.6. Maintenance. The Common Areas, together with all utilities, easements and amenities located within the Common Areas and not otherwise maintained by public entities or utilities, shall be maintained by the Declarant until December 31, 1995, at which time the Association shall activate the collection of the initial Annual Assessment from each Owner for such maintenance to the Common Areas. Maintenance of the Private Road shall be performed by Declarant until December 31, 1995, and thereafter maintenance of the Private Road will be the sole responsibility of the Private Road Lot Owners (enforceable by any Private Road Lot Owner). Provided, however, in accordance with Section 12.1 of this Declaration, Declarant hereby reserves the right and easement, but not the obligation, to go upon any portion of the Common Areas and Private Road at any time in order to repair and maintain such Common Areas and Private Road where needed, in Declarant's sole discretion, to bring such Common Areas and Private Road within the standards required by Declarant (including the Public Roads prior to acceptance for public maintenance by the Oconee County Public Works Department or other governmental authority). Should Declarant so go upon the Common Areas to perform maintenance and repairs for such purpose, the Association hereby agrees to reimburse Declarant in full for the cost of such maintenance and repairs to the Common Areas, upon receipt of a statement for such cost from Declarant. Furthermore, should the Declarant perform

maintenance and repairs for such purpose to the Private Road, each Private Road Lot Owner shall be obligated to the Declarant for his or her share of all related costs of such maintenance and repairs incurred by Declarant.

The Common Areas and Private Road shall be maintained as more particularly described below:

(a) Maintenance of the Entrance Monuments shall include maintenance, repair and reconstruction, when necessary, of the stone monuments, signage, irrigation, planters and lighting located thereon and providing and paying for landscaping, utility charges for irrigation and lighting of the stone monuments and signage located thereon.

(b) Maintenance of the Piers and Boatslips shall include the maintenance, repair and reconstruction, when necessary, of the Piers and Boatslips, including all structures, lighting, and other fixtures, wire, railings, and other facilities located thereon, and providing and paying for utility charges therefor.

(c) All Common Areas, including, but not limited to, the Public Roads (prior to governmental acceptance for operation and maintenance) and medians, the Entrance Monument, Amenity Area, Boat Storage Area, Piers and Boatslips (and all improvements located thereon) shall be clean and free from debris and maintained in an orderly condition, together with the landscaping thereon (if any) in accordance with the highest standards for private parks, including any removal and replacement of any landscaping, utilities, or improvements located thereon.

(d) Maintenance of the Boat Storage Area shall include the maintenance, cleaning and repair, when necessary, of any improvements located on the Boat Storage Area, including all lighting, fixtures, wire, gravel area and other facilities (if any) located thereon, and providing and paying for utility charges therefor.

(e) Maintenance of the Amenity Area shall include the maintenance and repair of the landscaping, lighting, irrigation, pathways and other improvements, repairs and reconstruction of the pavement, and providing and paying for irrigation and utility charges (if any).

(f) Maintenance of the Clubhouse shall include all interior and exterior maintenance (including, where necessary, repair and reconstruction) of the Clubhouse building, sidewalks, walkways, landscaping and other facilities appurtenant to the Clubhouse, and the payment of all utility charges therefor.

(g) Maintenance of the Pool shall include the maintenance, repair and reconstruction, where necessary, of the Pool, including



FILED FOR REC'D
000 SEE COUNTY
S.O.
MAY 27 4 22 PM '95
JILLIE O. SMITH
CLERK OF COURT

all drainage, lighting, fencing, paving and other facilities appurtenant thereto, and the payment of all utility charges therefor.

(h) Prior to acceptance for public maintenance, the Public Roads shall be maintained by the Association, provided that the Declarant, in its sole discretion, has the right to reimburse the Association for maintenance cost until the Public Roads are accepted for maintenance by the Oconee County Public Works Department or other governmental entity. Such maintenance shall include repair and reconstruction, when necessary. Maintenance of the Public Roads shall conform to the standard of maintenance (if one is ascertainable) which would be required by the Oconee County Public Works Department or other governmental entity before it would accept such Public Roads for maintenance.

(i) The Private Road located within the Private Road Easement which will serve the Private Road Lots shall be maintained and repaired by the Private Road Lot Owners. Such maintenance shall include repair and reconstruction, when necessary, as more particularly set forth in Section 4.15 of this Declaration.

(j) Maintenance of the Parking Area shall include repair, maintenance and reconstruction, when necessary, of the pavement; and irrigation and landscaping (if any), as necessary, and the payment of the electrical costs of lighting and irrigation (if any).

(k) The Association shall not be responsible for the maintenance of any Lot or any portion of any Lot or the improvements within the boundaries thereof. The Owners of such Lots shall be responsible for same.

Section 4.7. Reserve Fund. The Association shall establish and maintain an adequate reserve fund for the periodic maintenance, repair and replacement of improvements located on all Common Areas and the Public Roads (prior to acceptance) which the Association is obligated to maintain and in order to fund unanticipated expenses of the Association or to acquire equipment or services deemed necessary or desirable by the Board of Directors. Such reserve fund shall be collected and maintained out of the Annual and Boatslip Assessments, as hereinafter defined, and as set forth in Section 5.2(i) and Section 6.2(g).

Section 4.8. Piers and Boatslips. Declarant and the Association shall have the exclusive right to construct some or all of the Piers and Boatslips (including all improvements located thereon), in the approximate locations shown on the Map and on Exhibit "C", as well as any additional Piers and Boatslips which may be added to the Development in the future pursuant to the provisions of this Declaration. Neither Declarant nor the Association shall construct more Boatslips than are approved by



FILED FOR RECO
OCONEE COUNT
S.O.
NOV 28 4 22 PM
2004.4
SALLIE O. SMIT
CLERK OF COURT

Duke Power Company pursuant to Declarant's boatslip permit request for the Subdivision.

(a) Upon the construction of one or more Piers and Boatslips as set forth above, Boatslips shall be designated for the exclusive use of the Owners of certain Lots and transferred among Owners as follows:

(i) In a recorded deed or other recorded instrument, Declarant may designate one numbered Boatslip as an appurtenance to any Boatslip Lot. The Lot to which a Boatslip is designated as an appurtenance shall thereafter be a Boatslip Lot subject to the provisions of subparagraph 8(a)(ii) below. Such recorded deed or other recorded instrument shall operate to grant the Boatslip Lot Owner the exclusive right to use the designated Boatslip. The creation of a Boatslip Lot shall be conclusively deemed to establish a valid sublease of the designated Boatslip from the Association to the Owner of a Boatslip Lot for as long as such Lot shall remain a Boatslip Lot. Once designated in such deed or other recorded instrument, the exclusive right to use the designated Boatslip shall not be separated from ownership of the Boatslip Lot to which it is appurtenant, but, rather, shall run with the title to such Boatslip Lot unless and until the right to use the designated Boatslip is conveyed by recorded deed or other instrument as set forth in subparagraph 8(a)(ii). Any deed, deed of trust, mortgage, transfer or other conveyance or encumbrance of a Boatslip Lot shall also transfer, convey or encumber (as the case may be) the right to use the Boatslip appurtenant thereto, even if not expressly included therein.

(ii) The exclusive right to use a particular Boatslip may be conveyed by recorded deed or other recorded instrument to another Owner. Upon such conveyance, the transferor's Lot shall cease to be a Boatslip Lot and the transferee's Lot shall thereafter be a Boatslip Lot, in which case the right to use the transferred Boatslip shall then run with the title to such Boatslip Lot as set forth in subparagraph 8(a)(i) above. A Boatslip may not be conveyed, assigned or leased to anyone or any entity other than an Owner or the Association.

(b) Declarant shall have the right to use and shall have the obligation to pay Boatslip, Supplemental Boatslip and Special Boatslip Assessments on any Boatslips constructed by it and not conveyed to an Owner.

(c) In the event that there are more Boatslips than there are Boatslip Lots in the Subdivision, then any Boatslip which is not designated as an appurtenance to a Boatslip Lot shall remain the property of the Association. Such an undesignated Boatslip shall be owned by the Association for the common use and enjoyment only of the Owners of Boatslip Lots, their families, guests and invitees, for the purpose of temporarily docking boats, and may not

be leased by the Association to, or used by, any other party or the public. No boat or other recreational vehicle shall be permitted to remain overnight in any undesignated Boatslip.

The construction, placement and use of the Piers and Boatslips are and shall be subject to each of the following:

- (i) rules and regulations for use promulgated by the Association;
- (ii) all laws, statutes, ordinances and regulations of all federal, state and local governmental bodies having jurisdiction thereon;
- (iii) rules and regulations for use established by Duke Power Company, its successors and assigns; and
- (iv) the terms of the Lease between Duke Power Company, as lessor, and The Summit Owners' Association, as lessee, covering the area leased from Duke Power Company within which the Piers and Boatslips are located.

(d) The Board of Directors, pursuant to the Bylaws attached hereto as Exhibit "B", shall adopt rules and regulations governing the use of the Piers and Boatslips and the personal conduct thereon of the Members owning Boatslip Lots and their families, guests, invitees and tenants. Should Members owning Boatslip Lots desire to amend such rules and regulations, then a meeting of the Members owning Boatslip Lots may be called and held, in accordance with Article 3 of the Bylaws, for the purpose of voting to amend such rules and regulations. If such a meeting is duly called and held, the Boatslip Lot Owners may direct the Board of Directors to make such amendments to the rules and regulations governing the use of the Piers and Boatslips, including additions to and deletions of portions of such rules and regulations, as are approved by a vote of the Members owning Boatslip Lots, in accordance with Article 3 of the Bylaws, and as are permitted under the Association's lease with Duke Power Company as to the lake bed over which the Piers and Boatslips are located.

(e) Piers may only be used by Owners of Boatslip Lots, their families, guests, invitees or tenants occupying the Boatslip Lot. Each Boatslip may only be used by the Owner(s) of the Boatslip Lot to which such Boatslip is designated, their families, guests, invitees or tenants occupying the Boatslip Lot.



FILED FOR RECORD
 OCHEE COUNTY
 S.C.
 NOV 27 4 22 PM 1995
 SALLIE G. SMITH
 CLERK OF COURT

Section 4.9. Parking Area. Declarant shall construct, and the Association shall maintain, repair and, if destroyed, replace, as a common expense of the Association, the paved Parking Area on and over a portion of the Amenity Area. The Parking Area shall be constructed and maintained in order to provide parking for the Owners, and may be used only by Declarant and its assigns and the Owners, their families, guests and invitees in connection with their use of the Amenity Area. Accordingly, the maintenance, repair and replacement costs of the Parking Area shall be assessed against all Owners as set forth in Article 5 of the Declaration.

Section 4.10. Pool. Declarant shall construct and the Association shall maintain the Pool over a portion of the Amenity Area. The Pool shall be constructed and maintained for the common use and benefit of the Owners and may be used only by Declarant and its assigns and the Owners, their families, guests and invitees.

Section 4.11. Clubhouse. Declarant shall construct and the Association shall maintain the Clubhouse on and over a portion of the Amenity Area. The Clubhouse shall be constructed and maintained for the common use and benefit of the Owners and may be used only by Declarant and its assigns and the Owners, their families, guests and invitees in connection with their use of the Amenity Area.

Section 4.12. Amenity Area. The Amenity Area, as reflected on the Map, shall be provided by Declarant and maintained and repaired by the Association as a common expense for the common use of the Owners (except as otherwise provided herein as to the Pier and Boatslip), their families, guests and invitees in order to provide access for the Owners, in connection with their use of the Parking Area, Clubhouse, Tennis Court, Pool and Boatslips and Pier located thereon or adjacent thereto.

Section 4.13. Tennis Court. Declarant shall construct and the Association shall maintain, repair and, if destroyed, replace, as a common expense of the Association, the Tennis Court located on the Amenity Area, for the common use of the Owners, their families, guests and invitees.

Section 4.14. Boat Storage Area. The Boat Storage Area, as shown on the Map, shall be graded and covered with gravel by the Declarant and maintained by the Association, for the use of all Owners, their families, guests and invitees on a first come first served basis, and shall be designated, upon completion, for the purpose of temporarily storing boats, and may not be leased by the Association to, or used by, any other party or the public.

Section 4.15. Private Road. Declarant and the Association shall have the exclusive right to construct the Private Road within the Private Road Easement, in the approximate location shown on the Map, as well as any additional Private Road which may be added to

the Development in the future pursuant to the provisions of this Declaration.

(a) Upon the construction of one or more Private Roads as set forth above, the Private Road shall be designated for the exclusive use of the Owners of the Private Road Lots. In a recorded deed, Declarant shall designate a portion of the Private Road as an appurtenance to each Private Road Lot owned. Such recorded deed shall operate to grant the Private Road Lot Owner the right to use the designated Private Road. Once designated in such deed or other recorded instrument, the right to use the designated Private Road shall not be separated from ownership of the Private Road Lot to which it is appurtenant, but, rather, shall run with the title to such Private Road Lot. Any deed, deed of trust, mortgage, transfer or other conveyance or encumbrance of a Private Road Lot shall also transfer, convey or encumber (as the case may be) the right to use the Private Road appurtenant thereto, even if not expressly included therein.

(b) Declarant shall have the right to use and shall have the obligation to pay Private Road Assessments on any Private Road Lot not conveyed to an Owner.

(c) The Private Road Lot Owners shall meet from time to time to agree upon service work to be performed on the Private Road. Any Private Road Lot Owner may call a meeting by mailing written notice to each Private Road Lot Owner's residence at least thirty (30) days prior to the meeting which notice specifies that a vote may be taken regarding maintenance and repair of the each of the Private Road. Failure to notify every Private Road Lot Owner of the meeting in the manner prescribed above shall invalidate any vote taken at such meeting unless all Private Road Lot Owners attended the meeting in person or by proxy. A validly called meeting may be conducted by telephone or other convenient method. There shall be one vote appurtenant to each Private Road Lot and any repair or maintenance of the Private Road which is approved by a majority of the votes cast, in person or by proxy, at a validly called meeting shall be considered "Approved Maintenance." The cost of all Approved Maintenance shall be divided equally among the Private Road Lot Owners in proportion to the number of Lots which each of the Private Road Lot Owners own.

(d) Each Private Road Lot Owner shall be obligated for its share of the cost of all Approved Maintenance, the payment of which is enforceable by any Private Road Lot Owner. A lien is hereby established on Lots 46 and 47 of Phase I for the purpose of enforcing the obligations of any Private Road Lot Owner who fails to pay that Private Road Lot Owner's share of the cost of the Approved Maintenance of such Private Road. If a Private Road Lot Owner fails to pay his or her share of the costs of the Approved Maintenance, the defaulting Private Road Lot Owner shall pay interest accruing thereon at the lower of: (i) eighteen percent

(18%) per annum or; (ii) the maximum rate allowed by law. Additionally, if any Private Road Lot Owner is required to employ an attorney to collect the obligations hereunder from a defaulting Private Road Lot Owner or enforce the lien hereunder against a defaulting Private Road Lot Owner, such Private Road Lot Owner shall be reimbursed by the defaulting Private Road Lot Owner for all reasonable attorney's fees and court costs incurred with respect thereto.

(e) Except as otherwise expressly set forth herein, the Private Road may only be used by Owners of Private Road Lots, their families, guests, invitees or tenants occupying the Private Road Lot.

ARTICLE 5

COVENANT FOR ANNUAL AND SPECIAL ASSESSMENTS

Section 5.1. Creation of the Lien and Personal Obligation for Annual, Supplemental Annual, Special and Special Individual Assessments. The Declarant, for each Lot owned within the Property, hereby covenants, and each Owner of any Lot by acceptance of a deed therefor, whether or not it shall be so expressed in such deed, is deemed to covenant and agree to pay to the Association Annual Assessments, Supplemental Annual Assessments, Special Assessments and Special Individual Assessments, as hereinafter defined, established and collected as hereinafter provided. Any such assessment or charge, together with interest, costs, and reasonable attorneys' fees, shall be a charge and a continuing lien upon the Lot against which each such assessment or charge is made. Each such assessment or charge, together with interest, costs and reasonable attorneys' fees, shall also be the personal obligation of the Owner of such Lot at the time when the assessment fell due. The personal obligation for delinquent assessments or charges shall not pass to an Owner's successors in title unless expressly assumed by them.

Section 5.2. Purpose of Annual Assessments. The assessments to be levied annually by the Association against each Lot ("Annual Assessments") shall be used as follows:

- (a) to repair, maintain, reconstruct (when necessary) and keep clean and free from debris, the Common Areas and any amenities and improvements located thereon, including, but not limited to, the Entrance Monuments, Clubhouse, Pool, Tennis Court, Parking Area, Amenity Area, Boat Storage Area and Public Roads (prior to acceptance by local governmental authorities), (but excluding the Piers and Boatslips) and any improvements associated therewith, and to maintain landscaping thereon in accordance with the highest standards for private parks, including any

- necessary removal or placement of landscaping, as more particularly set forth in Article 4 of this Declaration;
- (b) to maintain and repair or caused to be maintained the Public Roads to the standards of the maintenance (if one is ascertainable) which would be required by the County of Oconee Public Works Department or other governmental entity before it would accept such Public Road for maintenance, as more particularly set forth in Article 4;
 - (c) to clean, maintain, repair and reconstruct, when necessary, the Boat Storage Area, including all improvements located thereon, including the maintenance, repair and replacement, when necessary, of any landscaping around the Boat Storage Area, all as more particularly set forth in Section 4.6 and Section 4.14 of this Declaration;
 - (d) to provide and pay for lighting of the Boat Storage Area (if any) to the extent necessary for the safety and enjoyment of the users thereof;
 - (e) to pay all costs associated with the lease of the Street Lights from Duke Power Company, including but not limited to, monthly lease payments and utility costs;
 - (f) to pay all ad valorem taxes levied against the Common Areas and any other property owned by the Association (other than the Piers and Boatslips, and any improvements located thereon, and any other property owned in connection therewith);
 - (g) to pay the premiums on all insurance carried by the Association pursuant hereto or pursuant to the Bylaws, except for such insurance carried specifically in connection with the Piers and Boatslips, and any improvements located thereon;
 - (h) to pay all legal, accounting and other professional fees incurred by the Association in carrying out its duties as set forth herein or in the Bylaws, except for such fees incurred specifically in connection with the Piers and Boatslips; and
 - (i) to maintain contingency reserves as to the amounts described in subsections (a) through (c) above for the purposes set forth in Section 4.7 hereof in amounts as determined by the Board of Directors.

Section 5.3. Payment of Annual Assessments; Due Dates. The Annual Assessment provided for herein shall commence as to each Lot on January 1, 1996. The Annual Assessment for the calendar year

beginning January 1, 1996, shall be Five Hundred and No/100s Dollars (\$500.00) per Lot, which amount shall be due and payable in advance no later than January 31 of the year in which such Annual Assessment is due, and pro-rated on a calendar year basis. The Annual Assessment for each and every year beginning January 1 thereafter shall be in an amount as set by the Board of Directors, in accordance with Section 5.4 and shall be due and payable in two (2) equal installments on January 31 and July 31 of each such calendar year. The Board of Directors shall fix the amount of the Annual Assessment as to each Lot for any calendar year at least thirty (30) days prior to January 1 of such calendar year, and the Association shall send written notice of the amount of the Annual Assessment, as well as the amount of the first installment due, to each Owner on or before January 1 of such calendar year. Failure of the Association to send, or of an Owner to receive, such notice shall not relieve any Owner of its obligation to pay Annual Assessments. Notwithstanding the foregoing, the Board of Directors may alter the dates of the fiscal year for setting the Annual Assessments and may increase or decrease the frequency of collection of Annual Assessment installments in any reasonable manner.

Section 5.4. Maximum Annual Assessment.

(a) For years following the first Annual Assessment and thereafter, the Board of Directors, by a vote in accordance with the Bylaws, without a vote of the Members, may increase the Annual Assessment each year by a maximum amount equal to the previous year's Annual Assessment times the greater of (i) ten percent (10%), or (ii) the annual percentage increase in the Consumer Price Index, All Urban Consumers, United States, All Items (1982-84 = 100) (hereinafter "CPI") issued by the U.S. Bureau of Labor Statistics for the most recent 12-month period for which the CPI is available. If the CPI is discontinued, then there shall be used the index most similar to the CPI which is published by the United States Government indicating changes in the cost of living. If the Annual Assessments are not increased by the maximum amount permitted under the terms of this provision, the difference between any actual increase which is made and the maximum increase permitted for that year shall be computed and the Annual Assessments may be increased by that amount in a future year, in addition to the maximum increase permitted under the terms of the preceding sentence for such future year, by a vote of the Board of Directors, without a vote of the Members.

(b) From and after the first year of Annual Assessments, the maximum annual assessment may be increased above the maximum amount set forth in subparagraph (a) of this Section 5.4 by a vote of two-thirds (2/3) of each class of Members who are voting in person or by proxy, at a meeting duly called for this purpose.

(c) The Board of Directors may fix the Annual Assessment at an amount not in excess of the maximum set forth in Subparagraph (a) of this Section 5.4 (the "Maximum Annual Assessment"). If the Board of Directors shall levy less than the Maximum Annual Assessment for any calendar year and thereafter, during such calendar year, determine that the important and essential functions of the Association cannot be funded by such lesser assessment, the Board may, by vote in accordance with the Bylaws, levy a supplemental Annual Assessment ("Supplemental Annual Assessment"). In no event shall the sum of the Annual and Supplemental Annual Assessments for any year exceed the applicable Maximum Annual Assessment for such year other than as set forth in Section 7.2 hereof.

Section 5.5. Special Assessments for Capital Improvements. In addition to the Annual Assessment authorized above, the Association may levy, in any assessment year, a special assessment ("Special Assessment") applicable to that year only for the purpose of defraying, in whole or in part, the cost of (i) the construction of any Common Area improvements which are not originally constructed by Declarant; or (ii) the reconstruction, repair or replacement of the Common Areas, including but not limited to, the Amenity Area, Public Roads (prior to acceptance for public maintenance by governmental authorities), Pool, Clubhouse, Tennis Court, Parking Area, Boat Storage Area, Street Lights or Entrance Monument (but excluding Boatslips and Piers) including all improvements located thereon, including fixtures and personal property related thereto. Provided that any such assessment must be approved by a vote of no less than two-thirds (2/3) of the votes of each class of Members who are voting in person or by proxy at a meeting duly called for this purpose.

Section 5.6. Special Individual Assessments. In addition to the Annual Assessments and Special Assessments authorized above, the Board of Directors shall have the power to levy a special assessment applicable to any particular Lot Owner ("Special Individual Assessment") (i) for the purpose of paying for the cost of any construction, reconstruction, repair or replacement of any damaged component of the Common Areas, including, but not limited to, the Amenity Area, Public Roads (prior to their acceptance for public maintenance), Pool, Entrance Monument, Street Lights, Boatslips, Pier, Tennis Court, Clubhouse, Parking Area or Boat Storage Area, including all improvements located thereon, whether occasioned by any act or omission of such Lot Owner(s), members of such Lot Owner's family, or such Lot Owner's agents, guests, employees or invitees and not the result of ordinary wear and tear; or (ii) for payment of fines, penalties or other charges imposed against any particular Lot Owner relative to such Lot Owner's failure to comply with the terms and provisions of this Declaration, the Bylaws or any rules or regulations promulgated by the Association or the Declarant pursuant to this Declaration or the Bylaws. Provided, however, that Declarant shall not be

obligated to pay any Special Individual Assessment except with Declarant's prior written approval. The due date of any Special Individual Assessment levied pursuant to this Section 5.6 shall be fixed in the Board of Directors resolution authorizing such Special Individual Assessment. Upon the establishment of a Special Individual Assessment, the Board shall send written notice of the amount and due date of such Special Individual Assessment to the affected Owner(s) at least thirty (30) days prior to the date such Special Individual Assessment is due.

Section 5.7. Assessment Rate.

(a) Subject to the exception set forth in subsection (b) below, Annual, Supplemental Annual and Special Assessments must be fixed at a uniform rate for all Lots.

(b) Annual, Supplemental Annual and Special Assessments for each Lot owned by Declarant and unoccupied as a residence shall be one-third (1/3) of the Annual, Supplemental Annual and Special Assessments for each other Lot in the Subdivision not owned by Declarant.

ARTICLE 6

COVENANT FOR BOATSLIP AND SPECIAL BOATSLIP ASSESSMENTS

Section 6.1. Creation of the Lien and Personal Obligation for Boatslip, Supplemental Boatslip and Special Boatslip Assessments. Declarant, for each Boatslip Lot owned within the Property, hereby covenants, and each Owner (including Approved Builder) of any Boatslip Lot by acceptance of a deed therefor, whether or not it shall be so expressed in such deed, or by acceptance of any other recorded instrument which designates a Boatslip as an appurtenance to such Owner's Lot as more particularly set forth in Section 4.8 of this Declaration, is deemed to covenant and agree to pay to the Association, in addition to the Annual, Supplemental Annual, Special and Special Individual Assessments provided for herein, Boatslip Assessments, Supplemental Boatslip Assessments and Special Boatslip Assessments, as hereinafter defined, for maintenance and repair costs of the Piers and Boatslips (including all improvements thereon) established and collected as hereinafter provided. Any such assessment or charge, together with interest, costs, and reasonable attorneys' fees, shall be a charge and a continuing lien upon the Boatslip Lot against which each such assessment or charge is made and upon the right to use the Pier and the Boatslip appurtenant to such Boatslip Lot. Each such assessment or charge, together with interest, costs and reasonable attorneys' fees, shall also be the personal obligation of the Owner of such Boatslip Lot effective at the time when the assessment falls due. The personal obligation for delinquent assessments or charges shall not pass to an Owner's successors in title unless expressly assumed by them.

Section 6.2. Purpose of Boatslip Assessments. The assessments to be levied annually by the Association against each Boatslip Lot ("Boatslip Assessments") shall be used as follows:

- (a) to clean, maintain, repair and reconstruct, when necessary, the Piers and Boatslips, including all lighting and other fixtures, wires, railings and other facilities located thereon (if any), all as more particularly set forth in Section 4.6 of this Declaration;
- (b) to provide and pay for lighting of and water service to the Piers and Boatslips (if any) to the extent necessary for the safety and enjoyment of the users thereof;
- (c) to pay all ad valorem taxes levied against the Piers and Boatslips and any other property owned by the Association in connection therewith;
- (d) to pay all lease payments, if applicable, to Duke Power Company for the lease of the land on which the Piers and Boatslips are located;
- (e) to pay the premiums on all insurance carried by the Association in connection with the Piers and Boatslips (including all improvements located thereon) pursuant hereto or pursuant to the Bylaws;
- (f) to pay all legal, accounting and other professional fees incurred by the Association in carrying out its duties as set forth herein or in the Bylaws in connection with the Piers and Boatslips (including all improvements located thereon); and
- (g) to maintain contingency reserves as to the amounts described in subsections (a) and (b) above for the purposes set forth in Section 4.7 hereof in amounts as determined by the Board of Directors.

Section 6.3. Payment of Boatslip Assessments; Due Dates. The Boatslip Assessments provided for herein shall be payable annually, in advance, and shall commence as to each Boatslip Lot (to which a completed Boatslip is appurtenant), and shall be due and payable thirty (30) days following the assignment of a completed Boatslip to a Boatslip Lot as set forth in Section 4.8 of this Declaration (such assessment shall be prorated from the date of such assignment through the remainder of the calendar year for which such assessment is due). Notwithstanding the foregoing, no Boatslip Assessments shall be due prior to January 1, 1996. The initial annual Boatslip Assessment (if assessed on or before January 1, 1997) shall be Two Hundred Seventy-Five and No/100s

Dollars (\$275.00) per Boatslip Lot and shall be due and payable no later than January 31 of the year in which such Boatslip Assessment is due, prorated on a calendar year basis. The Boatslip Assessments for each and every year thereafter shall be in an amount as set by the Board of Directors, in accordance with Section 6.4, and shall be due and payable no later than January 31 of each such year. The Board of Directors shall fix the amount of the Boatslip Assessment as to each Boatslip Lot for any year at least thirty (30) days prior to January 1 of such year, and the Association shall send written notice of the amount of the Boatslip Assessment to each Boatslip Lot Owner on or before January 1 of such year. Failure of the Association to send the notice described in this Section 6.3 shall not relieve the Owners of their liability for Boatslip Assessments. Notwithstanding the foregoing, the Board of Directors may alter the dates of the fiscal year for setting the Boatslip Assessments, and may increase or decrease the frequency of the collection of the Boatslip Assessments (or installments thereof) in any reasonable manner.

Section 6.4. Maximum Boatslip Assessment.

(a) For years following the first year of Boatslip Assessments and thereafter, the Board of Directors, by a vote in accordance with the Bylaws, without a vote of the Members, may increase the Boatslip Assessment each year by a maximum amount equal to the previous year's Boatslip Assessment times the greater of (i) ten percent (10%); or (ii) the annual percentage increase in the Consumer Price Index, All Urban Consumers, United States, All Items (1982-84=100) (hereinafter "CPI") issued by the U.S. Bureau of Labor Statistics for the most recent 12-month period for which the CPI is available. If the CPI is discontinued, then there shall be used the index most similar to the CPI which is published by the United States Government indicating changes in the cost of living. If the Boatslip Assessments are not increased by the maximum amount permitted under the terms of this provision, the difference between any actual increase which is made and the maximum increase permitted for that year shall be computed and the Boatslip Assessment may be increased by that amount in a future year, in addition to the maximum increase permitted under the terms of the preceding sentence for such future year, by a vote of the Board of Directors, without a vote of the Members.

(b) From and after the first year of Boatslip Assessments, the Boatslip Assessments may be increased without limitation if such increase is approved by a vote of no less than two-thirds (2/3) of each class of Members owning Boatslip Lots, at a meeting duly called for this purpose.

(c) The Board of Directors may fix the Boatslip Assessments at an amount not in excess of the maximum set forth in subparagraph (a) of this Section 6.4 (the "Maximum Boatslip Assessment"). If the Board of Directors shall levy less than the

Maximum Boatslip Assessment for any calendar year and thereafter, during such year, determine that the important and essential functions of the Association as to the Piers and Boatslips (and all improvements located thereon) cannot be funded by such lesser assessment, the Board may, by a vote in accordance with the Bylaws, levy a supplemental Boatslip Assessment ("Supplemental Boatslip Assessment"). In no event shall the sum of the Boatslip and Supplemental Boatslip Assessments for any year exceed the applicable Maximum Boatslip Assessment for such year other than as set forth in Section 7.2 hereof.

Section 6.5. Special Assessments for Boatslip Improvements. In addition to the Boatslip Assessments authorized above, the Association may levy, in any assessment year, a special Boatslip Assessment ("Special Boatslip Assessment") applicable to that year only for the purpose of defraying, in whole or in part, the cost of any reconstruction, repair or replacement of the Piers and Boatslips, and any capital improvement located thereon, including lighting, pathways, water lines and other fixtures, poles, wires, railings and other facilities located thereon and personal property related thereto. Provided that any such assessment must be approved by a vote of no less than two-thirds (2/3) of each of class of Members owning Boatslip Lots, taken at a duly held meeting of such Members in accordance with the Bylaws, and further provided that any such Special Boatslip Assessment may be levied only against the Owners of Boatslip Lots.

Section 6.6. Assessment Rate.

(a) Except as set forth in subsection (b) below, Boatslip, Supplemental Boatslip and Special Boatslip Assessments must be fixed at a uniform rate for all Boatslip Lots.

(b) Boatslip, Supplemental Boatslip and Special Boatslip Assessments for each Boatslip Lot owned by Declarant and unoccupied as a residence shall be one-third (1/3) of the Boatslip, Supplemental and Special Boatslip Assessments for each other Boatslip Lot in the Subdivision not owned by Declarant.

ARTICLE 7

GENERAL ASSESSMENT PROVISIONS

Section 7.1. Certificate Regarding Assessments. The Association shall, upon demand, and for a reasonable charge, furnish a certificate signed by an officer of the Association setting forth whether the assessments on a specified Lot have been paid. A properly executed certificate of the Association as to the status of assessments on a Lot is binding upon the Association as of the date of its issuance.

Section 7.2. Effect of Nonpayment of Assessments; Remedies of the Association. Any Annual, Special, Special Individual, Supplemental, Boatslip, Special Boatslip or Supplemental Boatslip Assessment (or installment thereof) not paid by its due date as set forth in Section 5.3 and Section 6.3 hereof, or any other assessment not paid by its due date, shall bear interest from such due date at the rate of eighteen percent (18%) per annum or the highest rate then permitted by law, whichever is less. In addition to such interest charge, the delinquent Owner shall also pay such late charge as may have been theretofore established by the Board of Directors to defray the costs arising because of late payment. The Association may bring an action at law against the delinquent Owner or foreclose the lien against the Lot and the right to use the Common Areas or a Boatslip, if applicable, and interest, late payment charges, costs and reasonable attorney's fees related to such action or foreclosure shall be added to the amount of such assessment. No Owner may waive or otherwise escape liability for the assessments provided for herein by not using the Common Areas and/or his Boatslip, if applicable, or by abandoning his Lot.

Section 7.3. Subordination of the Lien to Mortgages. The lien of the assessments provided for in Articles 5 and 6 of this Declaration shall be subordinate to the lien of any first Mortgage on a Lot or any mortgage or deed of trust to the Declarant. Sale or transfer of any Lot shall not affect the assessment lien. The sale or transfer of any Lot pursuant to mortgage foreclosure, or any proceeding in lieu thereof, however, shall extinguish the lien of such assessments as to payments which became due prior to such sale or transfer; provided, however, that the Board of Directors may in its sole discretion determine such unpaid assessments to be an Annual, Special, Supplemental, Boatslip, Special Boatslip or Supplemental Boatslip, as applicable, collectable pro rata from all Owners (or from all Boatslip Lot Owners if a Boatslip, Supplemental Boatslip or Special Boatslip Assessment), including the foreclosure sale purchaser. Such pro rata portions are payable by all Owners (or all Boatslip Lot Owners if a Boatslip, Supplemental Boatslip, or Special Boatslip Assessment), notwithstanding the fact that such pro rata portions may cause the Annual Assessment or Boatslip Assessment to be in excess of the Maximum Annual Assessment or Maximum Boatslip Assessment permitted hereunder. No sale or transfer shall relieve the purchaser of such Lot from liability for any assessments thereafter becoming due or from the lien thereof, but the lien provided for herein shall continue to be subordinate to the lien of any mortgage or deed of trust as above provided.

ARTICLE 8

RESTRICTIONS

Section 8.1. Land Use, Building Type and Residential Restrictions. All Lots in the Subdivision shall be known and described as residential lots and shall be used only for private

residential and recreational purposes. No structure shall be erected, altered, placed or permitted to remain on any Lot other than for use as a single family residential dwelling, unless otherwise provided herein, and only one single-family residential dwelling not exceeding 2½ stories in height above ground shall be erected or permitted to remain upon any Lot. No mobile home, modular home or shell home may be erected or permitted to remain on any Lot. A private garage, outbuildings, fixed piers and floating boat dock facilities incidental to the residential use of the Lot are expressly permitted upon the condition that they are not rented, leased nor otherwise used for remuneration, subject to the other covenants and restrictions contained herein. No detached garage or outbuildings shall at any time be used as a residence. Any ownership or leasing arrangement for a Lot having the characteristics of a vacation time sharing ownership plan, a vacation time sharing lease plan or shared ownership is hereby prohibited. Furthermore, no boat (including a houseboat), whether existing on a Lot or docked at a fixed pier or floating boat dock which is appurtenant to any Property in the Subdivision, may at any time be used as a residence.

Section 8.2. Dwelling Size. The square footage requirements hereinafter set forth are enclosed heated floor area and are exclusive of the area in unfinished basements, unheated porches of any type, attached or detached garages, carports, and unheated storage areas, decks or patios.

No dwelling erected upon any Lot shall contain less than 2,100 square feet, with not less than 1,800 square feet on the main floor.

Section 8.3. Building Construction and Quality. All buildings and outbuildings erected upon any Lot shall be constructed of new material of good grade, quality and appearance and shall be constructed in a proper, workmanlike manner. No single-family residential dwelling with a sales price of less than One Hundred Fifty Thousand and No/100 Dollars (\$150,000.00) (in terms of 1995 dollar value), exclusive of the Lot, shall be permitted on any Lot, unless approved in advance, in writing, by the Declarant or the Board of Directors. No building shall be erected unless it is completely underpinned with a solid brick or brick, stone or stucco covered block foundation. The exterior surface of any building shall not be of vinyl siding, asbestos shingle siding, imitation brick or stoneroll siding, or exposed concrete or cement blocks. The exterior surface of any garage, outbuilding or appurtenant structure or building erected on or located on any Lot shall be architecturally compatible with, and of material and construction comparable in cost and design to, the exterior surface of the dwelling located on said Lot. All buildings shall have roofs (except for dormers and other minor architectural details) of not less than 6 in 12 pitch and not less than 12 inch overhang, covered with slate, cedar shakes, tile or

fiberglass shingles. Tin or rolled roofing material is not permitted (except for copper). The exterior of all houses and other structures must be completed within one (1) year after the commencement of construction, except where such completion is impossible due to strikes, fires, national emergency or natural calamities.

Section 8.4. Temporary Structures; Structure Materials. No residence or building of a temporary nature shall be erected or allowed to remain on any Lot, and no metal, fiberglass, plastic, vinyl or canvas tent, barn, carport, garage, utility building, storage building, or other metal, fiberglass, plastic, vinyl or canvas structure shall be placed or erected on any Lot or attached to any residence. Provided, however, that nothing herein shall prohibit Declarant or an Approved Builder from erecting or moving temporary buildings or trailers onto the Lots owned by them, to be used for storage or for construction or sales offices.

Section 8.5. Building Setback Lines. No building on any Lot (including any stoops, porches, or decks) shall be erected or permitted to remain within the front street right-of-way or side abutting right-of-way (for a corner Lot) building setback lines as noted on the Map. Notwithstanding any rear setback restrictions noted on the Map, no building, including stoops, porches or decks (whether attached or unattached), shall be erected or permitted to remain nearer than fifty (50) feet to the rear (waterside) lot line of any Lot adjoining the waters of Lake Keowee. For purposes of this restriction, the waterside lot line shall mean the contour line of Lake Keowee as noted on the Map. Boathouses, piers and dock facilities are exempt from the rear setback restrictions provided they comply with the provisions set forth in Section 8.21. The foregoing notwithstanding, gazebos or similar minor aesthetic improvements may encroach within the rear setback, including the fifty-foot waterside setback, provided that they (i) are single story, (ii) contain less than one hundred fifty (150) square feet, and (iii) are not enclosed by walls or other surfaces unless such surfaces meet the openness test established for perimeter fencing in Section 8.10. Similarly, front, side or rear entryways which (i) are connected to the residence and (ii) are not covered or enclosed in any manner, may encroach within the front, side, rear, or fifty-foot waterside setback.

In the event any zoning or subdivision ordinance, floodway regulations or other ordinance, law or regulation applicable to a Lot shall prescribe greater setbacks, then all buildings erected during the pendency of that zoning or subdivision ordinance, floodway regulations or other ordinance, law or regulation shall conform to said requirements. No masonry mailboxes or other structures or improvements may be constructed or placed within the right-of-way of any Public Road so as to prevent such Public Road from being accepted for maintenance by the Oconee County Public Works Department or other applicable governmental entity.

Declarant hereby reserves the right and easement, benefitting Declarant and the Association and burdening the Property, to go upon any Lot or other portion of the Property in order to remove any mailboxes or other structures or improvements constructed within the right-of-way of any Public Road so as to prevent such Public Road from being accepted for maintenance by the Oconee County Public Works Department or other applicable governmental entity. Should Declarant or the Association exercise its easement rights pursuant to the terms of this Section 8.5 the Owner of the nonconforming Lot shall reimburse Declarant or the Association (as applicable) within five (5) business days following the submission of an invoice for any costs or expenses incurred by Declarant or the Association. The exercise or nonexercise of the easement rights contained in this Section 8.5 shall be subject to the discretion of the Declarant and the Association and neither Declarant nor the Association shall have the obligation to exercise such rights.

The Association shall have the authority but not the obligation, in its sole discretion, to assess penalties against an Owner who fails to abide by the terms of this Section 8.5. The penalties authorized by this Section 8.5 as well as the expenses to be reimbursed Declarant or the Association shall be considered Special Individual Assessments against the respective Owner's Lot, entitling the Association to the assessment collection remedies specified in Article 7 of this Declaration.

Section 8.6. Minor Setback Violations. In the event of the unintentional violation of any of the building setback covenants set forth above, in the amount of ten percent (10%) or less of the setback covenant in question, the Association or the Declarant reserves the right, but is not obligated, to waive in writing such violation of the setback covenants upon agreement of the Owner of the Lot upon which the violation occurs, provided that such change is not in violation of any zoning or subdivision ordinance or other applicable law or regulation. Notwithstanding the foregoing, so long as Declarant owns a Lot in the Subdivision, all such waivers must be consented to in writing by Declarant.

Section 8.7. Combination or Subdivision of Lots. Except as otherwise set forth herein, no Lot shall be subdivided by sale or otherwise so as to reduce the Lot area shown on the Map. However, an Owner of a Lot may combine with a portion of or all of another contiguous Lot so long as the parcel or parcels which result from such combination do not violate any applicable zoning ordinance or other applicable law or regulation. In the event that two or more Lots are completely combined so as to create one parcel, the resulting parcel shall be considered as one Lot for the purposes of this Article 8, but shall continue to be considered as two Lots for all other purposes (including voting and assessments). Furthermore, the Owner of any Lot which combines with all or a portion of a contiguous Lot shall be solely responsible for any

costs which may result from such combination, including the costs of relocating any existing easements. Notwithstanding the foregoing, Declarant reserves the right to change the boundaries or dimensions of any Lots still owned by Declarant or an Approved Builder as may be needed to meet septic system requirements or for any other reason and any Lot or Lots which result from such change shall not be subject to any additional assessment.

Section 8.8. Utility Easements. Declarant hereby reserves easements for the installation and maintenance of utilities (electricity, septic system, sewer, water, gas, telephone, cable t.v., etc.) and drainage facilities over the front and rear ten (10) feet of each Lot (with the exception of the waterfront Lots, which will not have a ten [10] foot easement over the rear [i.e., waterside]) and five (5) feet in width along each side lot line of each Lot. Additional drainage easements and utility easements are reserved as more particularly shown and delineated on the Map and in other recorded easement documents. Within such easements, no structure, planting or other materials shall be placed or permitted to remain which may damage or interfere with the installation and maintenance of utilities or which may interfere with drainage and the flow of water within the easement areas. The Owner of each Lot shall maintain that portion of the Lot lying within the easement areas as defined herein and shall maintain any improvements located thereon, except those improvements installed and maintained by a public authority or utility company. Declarant reserves the right to create and impose additional easements over any unsold Lot or Lots for street drainage, utility and entry signage installation purposes by the recording of appropriate instruments, and such shall not be construed to invalidate any of these covenants.

Section 8.9. Entrance Monument Easement. Declarant hereby reserves a non-exclusive perpetual easement for the purpose of landscaping and maintaining the entryway and erecting and maintaining the Entrance Monument for the Subdivision. An easement is hereby reserved by Declarant for itself, its successors in interest and assigns, and granted to the Association over portions of the parcel labeled "Common Open Space" on the Map at the entrance of the subdivision, and shown as "Entrance Monument Easement" on the Map (the "Easement Tract").

Declarant or the Association shall have the right to enter, landscape and maintain the Easement Tract as an entryway to the Subdivision. Further, Declarant or the Association shall erect and maintain one or more stone monuments, with an entrance sign thereon (collectively, the "Entrance Sign") bearing the name of the Subdivision and Declarant, which Entrance Signs shall be built to the applicable governmental standards for signs; and to erect and maintain lighting for the Entrance Sign, planters and other improvements typically used for an entryway (the Easement Tract, the Entrance Sign, lighting, landscaping, irrigation and other improvements to be constructed on the Easement Tract are herein

collectively referred to as the "Entrance Monument Easement" on the Map).

Section 8.10. Fences and Walls. Fences and walls may be constructed of wood, brick or stone. Chain link or other metal fencing is not permitted, except that 2" x 4" metal mesh may be used with split rail fencing to contain animals or children within rear or sideyards only. Perimeter fencing shall not have more than seventy percent (70%) of any of its surface closed as viewed from a point on a line of sight perpendicular to the line of the fence. A wall constructed of brick or stone and used in lieu of a fence is exempt from the openness test. No fences or walls greater than six (6) feet in height are permitted.

No fence or wall facing the street shall be erected on a Lot nearer the street right of way line than the front face of the dwelling located on such Lot, except for split-rail fencing or fencing not higher than 30" in height. In the case of a corner Lot, no sideyard fence or wall shall be erected nearer the street right of way line than the side of the dwelling located on such Lot, except for split-rail fencing or fencing no higher than 30" in height. Provided, however, that the Restrictions described in this Section 8.10 shall not apply to any improvements originally installed by Declarant on any Common Area.

Section 8.11. Signs. No signs of any kind may be displayed to the public view on any Common Area other than the Entrance Monument as set forth in Section 8.9 above. No signs of any kind may be displayed to the public view on any Lot with the following exceptions which may not exceed five (5) square feet in size: (a) one sign (on the Lot only) advertising the property for sale; and (b) one sign (on the Lot only) used by an Approved Builder to advertise the Lot during the construction and sales period; and (c) temporary political signs. These restrictions shall never apply to permanent Entrance Monuments, or to temporary entry signs or advertising by Declarant, or an Approved Builder, or "for sale" signs installed by Declarant, Approved Builder or its agents prior to the sellout of the Subdivision.

Section 8.12. Antennas; Satellite Dishes or Discs. No freestanding radio or television transmission or reception towers, antennas, discs or satellite dishes which exceed eighteen inches in diameter may be erected or maintained on any Lot. Provided however, that (a) customary roof-mounted antennas which may extend not more than ten (10) feet above the highest roof line ridge of the house are permitted and (b) satellite discs or dishes which are eighteen inches (18") in diameter or less are permitted provided they are not visible from the Public and Private Roads or the waterside lot line of any Lot adjoining the waters of Lake Keowee.

Section 8.13. Lot Maintenance; Trash Disposal. Each Owner shall keep his Lot in a clean and orderly condition and shall keep

the improvements thereon in a suitable state of painting and repair, promptly repairing any damage thereto by fire or other casualty. No clothes line may be erected or maintained on any Lot. No Lot shall be used in whole or in part for storage of trash of any character whatsoever and no trash, rubbish, stored materials or similar unsightly items shall be allowed to remain on any Lot outside of an enclosed structure, except when temporarily placed in closed, sanitary containers pending collection by trash collection authorities or companies.

Section 8.14. Off-Street Parking; Off-Water Boat Storage. Each Lot Owner shall provide a concrete or asphalt driveway which provides space for parking two automobiles off the street prior to the occupancy of any dwelling constructed on the Lot. No truck or commercial vehicle in excess of one-ton load capacity, or any vehicle under repair, or any trailer or wrecked or junked motor vehicle shall be parked upon or permitted to remain on any Lot, the Boat Storage Area, Amenity Area, Parking Area or any other Common Area. No boat or boat trailer may be parked, left or stored on the Amenity Area except when using the Boatslips and Piers. No trailer, motor home, recreational vehicle, camper or boat shall be used as a residence either permanently or temporarily, or be parked upon or be permitted to remain on any Lot for a period exceeding 24 hours unless it is parked on the Boat Storage Area, or off the street and not within the front or side yard setbacks of the Lot.

All trucks, trailers, campers, boats, motor homes and recreational vehicles must have a current license plate affixed and must be parked in an enclosed garage. All other automobiles must have a current license plate affixed and must be parked in a carport, enclosed garage, or on a concrete or asphalt driveway, or on the Parking Area (when using the Amenity Area). Trailers of any type and boats on trailers shall be kept inside an enclosed structure and not within the fifty foot (50') waterfront setback. Provided however, no Owner shall ever have more than one (1) boat with a boat trailer stored on the Boat Storage Area for each Lot owned.

Section 8.15. Sewage Disposal. Every dwelling unit erected on any Lot shall be served by an approved septic system for the disposal of sewage, or connected to a private or public sewage disposal system. All septic systems or other private sewage disposal systems shall be approved by, and constructed and maintained in accordance with all the regulations and requirements of, all governmental authorities and regulatory agencies having jurisdiction. Declarant does not make any representations regarding the future availability of municipal sewer service.

Section 8.16. Nuisances. No noxious or offensive trade or activity shall be carried on upon any Lot or in any residential dwelling or outbuilding, nor shall anything be done thereon which may be or become an annoyance or nuisance to the neighborhood. No substance, thing or material shall be kept upon any Lot that will emit foul or obnoxious odors, or that will cause any noise that

will or might disturb the peace and quiet of the occupants of surrounding property. No animals, livestock, or poultry of any kind shall be raised, bred, or kept on any Lot or in any residential dwelling or outbuilding except that dogs, cats, or other household pets, which may be kept or maintained provided they are not kept, bred, or maintained for commercial purposes. The number of household pets kept or maintained, per Lot, shall not exceed three (3) in number except for newborn offspring of such household pets which are under nine (9) months in age.

Section 8.17. Diligent Construction. All construction, landscaping or other work which has been commenced on any Lot must be continued with reasonable diligence to completion and no partially completed houses or other improvements shall be permitted to exist on any Lot, except during such reasonable time period as is necessary for completion. The exterior of any building must be completed within one (1) year from the date of commencement of construction. No construction materials of any kind may be stored within any Public or Private Roads. Any damage to any street, curb or sidewalk or any part of any Common Area or any utility system caused by Declarant, Owner or Approved Builder shall be repaired by such responsible party. Declarant, Approved Builders and all Owners shall at all times keep contiguous public and private areas free from any dirt, mud, garbage, trash or other debris which is occasioned by construction of improvements on any Lot or Common Area. Declarant or the Association may provide for the cleaning of public and private areas due to the activities of the responsible party and may assess the responsible party a reasonable charge not to exceed the actual cost for such cleaning. Declarant and each Owner or Approved Builder shall, consistent with standard construction practices, keep all portions of their Lots and the Common Areas free of unsightly construction debris and shall at all times during construction either provide dumpsters for the containment of garbage, trash or other debris which is occasioned by construction of improvements on a Lot or Common Areas, or take other measures consistent with standard construction practices necessary to keep the Lot and all Common Areas free of such garbage, trash, or other debris. Declarant, any Approved Builder and each Owner shall be responsible for erosion control protection during any earth-disturbing operation, as described and defined in the "Erosion Control Practices" on Exhibit "D", attached hereto and incorporated herein by reference.

Section 8.18. Community Water System; No Private Individual Wells. Declarant shall cause to be constructed a water system in order to provide water supplies necessary to serve the Subdivision (the "Water System"). All water mains, pipes and other equipment necessary for the operation and maintenance of the Water System shall be located within the Utility Easements described in Section 8.8, or within the Private and Public Road rights-of-way. Upon its completion, the Water System and all mains, pipes and equipment and other personal property which is part thereof, shall become the

property of Seneca Light and Water. The Water System shall be the sole provider of water supplies to the Subdivision, and no well may be dug or constructed on any Lot for the purpose of providing domestic water supply.

Section 8.19. Removal of Trees and Other Vegetation. All trees, shrubs and ground cover within the 50' waterfront setback shown on the Map are considered to be "protected" vegetation in that cutting and clearing generally is not permitted therein without the prior written consent of Declarant or the Board of Directors. The practical exceptions to this rule are that dead or diseased trees may be removed and poisonous plants may be removed, underbrush may be selectively cleared, understory may be thinned to provide better views, individual trees may be limbed up, and grass or ground covers may be planted.

"Mature trees" inside the fifty (50') foot waterfront setback as shown on the Map may not be cut down or otherwise removed without the specific written approval of the Declarant or the Association. "Mature trees" for purposes of this Declaration shall mean all evergreen or deciduous trees with a caliper of six (6) inches or greater.

Furthermore, in the event that trees, shrubs or ground cover are completely removed (as opposed to thinned) in connection with the improvement of any Lot, such cleared portions of the Lot shall be covered with grass or shall be landscaped with plants, shrubs, trees, mulch, wood chips, pine needles and/or similar landscaping improvements.

Declarant hereby reserves the right and easement benefitting Declarant and the Association to go upon any Lot or other portion of the Property to replant or order the replanting of any trees, shrubs or other vegetation removed within the Subdivision in violation of the terms of this Section 8.19. Should Declarant or the Association exercise its easement rights pursuant to the terms of this Section 8.19, the Owner of the nonconforming Lot shall reimburse Declarant or the Association (as applicable) within five (5) business days following the submission of an invoice for any costs or expenses incurred by Declarant or the Association. The exercise or nonexercise of the easement rights contained in this Section 8.19 shall be subject to the discretion of the Declarant and the Association and neither Declarant, nor the Association shall have the obligation to exercise such rights.

Declarant and/or the Association shall have the authority but not the obligation, in their sole discretion, to assess penalties against an Owner who cuts, damages, or removes any trees, shrubs or other vegetation on any part of the Common Areas, its Lot or any other Lot or Common Area, contrary to the above provisions.

The penalties authorized by this Section 8.19, as well as all related expenses to be reimbursed, shall be considered Special Individual Assessments against the respective Owner's Lot, entitling the Association to the assessment collection remedies specified in Article 7 of this Declaration.

Section 8.20. Marine Toilets. No water craft equipped with a marine toilet having a fixed or portable holding tank, or a through hull or overboard discharge toilet, shall be permitted at any waterfront Lot Owners' docks or piers, the Piers or Boatslips shown on Exhibit C, or such additional Piers and Boatslips as are added pursuant to a Supplemental Declaration as set forth in Section 2.2.

Section 8.21. Docks, Piers and Boat Houses. The owner of any Lot adjoining the waters of Lake Keowee may construct one (1) pier, provided that such Lot is not located in an area where the narrowness of a cove precludes construction of a dock or pier as determined by Duke Power Company and/or any governmental entity having jurisdiction at the time such improvements are to be constructed. Any waterfront improvement shall have a low profile and open design to minimize obstruction of neighbors' views. Neither enclosed docks or boat houses, nor multiple-level docks or boat houses, will be allowed either on the water or within the fifty foot (50') waterfront setback. Roof-covered docks are allowed provided that such docks are one level and further provided that such docks are not enclosed. Provided, however, that the Piers and Boatslips shown on Exhibit C or such additional Piers and Boatslips as are added pursuant to a Supplemental Declaration set forth in Section 2.2 shall not be covered or roofed.

The placement, construction, or use of the Piers, Boatslips, and of any other pier, dock, boatslip structures or other improvements within or upon, or the conducting of any activity altering the topography of, the hydroelectric project surrounding and encompassing the waters of Lake Keowee, is and shall be subject to each of the following:

- (i) easements, restrictions, rules and regulations for construction and use promulgated by the Association;
- (ii) all laws, statutes, ordinances and regulations of all Federal, State and local governmental bodies having jurisdiction thereof, including without limitation the Federal Emergency Regulatory Commission; and
- (iii) rules and regulations, privileges and easements affecting the Property and the waters and submerged land of Lake Keowee established by Duke Power Company, its

successors and assigns. (Duke Power Company controls access to, and the use and level of, the waters of Lake Keowee. All Owners, the Association, the Declarant and Approved Builders must receive a permit from Duke Power [or a successor manager of Lake Keowee, under authority from the Federal Energy Regulatory Commission] prior to any alterations therein.)

No pier of any kind shall be constructed by Owners of Lots adjoining the waters of Lake Keowee outside the area designated as "Pier Zone" on Exhibit "F" attached hereto and incorporated herein by reference.

Section 8.22. Boat Ramps. No boat ramps of any kind shall be permitted on any Lot, and no boat shall be placed in (or removed from) the waters of Lake Keowee from any Lot, provided however, small watercraft such as canoes, dinghies, and jet skis may be launched from any Lot if launched without a ramp. All other watercraft shall be launched at a public boat ramp outside the Subdivision.

Section 8.23. Mailbox Structure Standards. Each Owner must construct and install a mailbox on his or her Lot which conforms to the community mailbox requirements reflected on Exhibit "E", and entitled "Standard Community Mailbox", attached hereto and incorporated herein by reference thereto.

ARTICLE 9

INSURANCE

Section 9.1. Board of Directors. The Board of Directors shall obtain and maintain at all times insurance of the type and kind and in no less than the amounts set forth below:

(a) Fire. All improvements and all fixtures included in the Common Areas, including but not limited to, the Piers, Boatslips, Boat Storage Area, Entrance Monuments, Clubhouse, Tennis Court, Pool, Public Roads (prior to acceptance for maintenance by a governmental authority) and medians located thereon, Amenity Area and Parking Area, and all personal property and supplies belonging to the Association, shall be insured in an amount equal to 100% of the current replacement cost up to the amount specified in the insurance policy (exclusive of land, foundation, excavation and other normally excluded items) as determined annually by the Board of Directors with the assistance of the insurance company providing coverage. The Board of Directors shall, at least annually, review the insurance coverage required herein and determine 100% of the current replacement cost of such improvements and fixtures and personal property and supplies. Such coverage shall provide protection against loss or damage by fire, windstorm, vandalism and

malicious damage and all perils covered by a standard "all risk" insurance policy. All such policies shall provide that adjustment of loss shall be approved by the Board of Directors and the insurance company. In addition to the provisions and endorsements set forth in Sections 9.3 and 9.4, the fire and casualty insurance described herein shall contain the following provisions:

(i) a waiver of subrogation by the insurer as to any claims against the Association, any officer, director, agent or employee of the Association, the Owners and their employees, agents, tenants and invitees; and

(ii) a provision that the coverage will not be prejudiced by act or neglect of one or more Owners when said act or neglect is not within the control of the Association or by any failure of the Association to comply with any warranty or condition regarding any portion of the Property over which the Association has no control.

The property and public liability insurance policy shall not contain (and the insurance shall not be placed with companies whose charters or bylaws contain) provisions whereby: (1) contributions or assessments may be made against the Association, the Owners or the Mortgagees; (2) loss payments are contingent upon action by the carriers, directors, policy holders or members; and (3) there are limiting clauses (other than insurance conditions) which could prevent Owners or Mortgagees from collecting the proceeds.

(b) Public Liability. The Board of Directors shall also be required to obtain and maintain to the extent obtainable, public liability insurance in such limits as the Board of Directors may, from time to time, determine to be customary for projects similar in construction, location and use to the Development, covering each member of the Board of Directors, the managing agent, if any, and each Owner with respect to his liability arising out of the ownership, maintenance, or repair of the Common Areas; provided, however, that in no event shall the amounts of such public liability insurance ever be less than \$1,000,000 per occurrence against liability for bodily injury, including death resulting therefrom, and damage to property, including loss of use thereof, occurring upon, in or about, or arising from or relating to, the property or any portion thereof. Such insurance shall include endorsements covering cross liability claims of one insured against another, including the liability of the Owners as a group to a single Owner. The Board of Directors shall review such limits annually. Until the first meeting of the Board of Directors following the initial meeting of the Owners, such public liability insurance shall be in amounts of not less than \$1,000,000 per occurrence for claims for bodily injury and property damage.

(c) Fidelity Coverage. The Board of Directors shall also be required to obtain fidelity coverage against dishonest acts

on the part of all persons, whether officers, directors, trustees, employees, agents or independent contractors, responsible for handling funds belonging to or administered by the Association, in an amount determined by the Board of Directors in its discretion. An appropriate endorsement to the policy to cover any persons who serve without compensation shall be added if the policy would not otherwise cover volunteers.

(d) Other. Such other insurance coverages, including flood insurance and worker's compensation, as the Board of Directors shall determine from time to time desirable.

Section 9.2. Premium Expense. Premiums upon insurance policies purchased by the Board of Directors shall be paid by the Board of Directors and charged as a common expense to be collected from the Owners pursuant to Articles 5 and 6 hereof.

Section 9.3. Special Endorsements. The Board of Directors shall make diligent effort to secure insurance policies that will provide for the following:

(a) recognition of any insurance trust agreement entered into by the Association;

(b) coverage that may not be cancelled or substantially modified (including cancellation for nonpayment of premium) without at least forty-five (45) days prior written notice to the named insured, any Insurance Trustee and all Mortgagees; and

(c) coverage that cannot be cancelled, invalidated or suspended on account of the conduct of any officer or employee of the Board of Directors without prior demand in writing that the Board of Directors cure the defect and the allowance of a reasonable time thereafter within which the defect may be cured by the Association, any Owner or any Mortgagee.

Section 9.4. General Guidelines. All insurance policies purchased by the Board of Directors shall be with a company or companies licensed to do business in the State of South Carolina and holding a rating of "A-10" or better by the current issue of Best's Insurance Reports. All insurance policies shall be written for the benefit of the Association and shall be issued in the name of, and provide that all proceeds thereof shall be payable to, the Association. Notwithstanding any of the foregoing provisions and requirements relating to insurance, there may be named as an insured, on behalf of the Association, the Association's authorized representative, who shall have exclusive authority to negotiate losses under any policy providing such insurance.

Section 9.5. Owner's Personal Property. The Association or the Declarant shall not be liable in any manner for the safekeeping or conditions of any boat or other personal property belonging to

or used by any Owner or his family, guests or invitees, located on or used at the Piers, Boatslips, Boat Storage Area, Amenity Area or other Common Areas. Further, the Association or the Declarant shall not be responsible or liable for any damage or loss to or of any boat, or any tackle, gear, equipment or other property located thereon, or any other personal property of any Owner, his family, guests or invitees located on or used at the Piers, Boatslips, Amenity Area, Boat Storage Area or other Common Areas. Each Owner shall be solely responsible for all such boats and other personal property and for any damage thereto or loss thereof, and shall be responsible for the purchase, at such Owner's sole cost and expense, of any liability insurance or other insurance for damage to or loss of such property. Every Boatslip Lot Owner is required to submit to the Association a Certificate of Insurance showing proof of boat liability insurance coverage at the time of initiating the use of the Piers and Boatslips.

ARTICLE 10

RIGHTS OF MORTGAGEES

Section 10.1. Approval of Mortgagees. Unless at least seventy-five percent (75%) of the Mortgagees holding Mortgages on Lots located within the Development then subject to the full application of this Declaration have given their prior written approval, the Association shall not:

(a) except as otherwise specifically provided herein, by act or omission seek to abandon, partition, subdivide, encumber, sell or transfer any real estate or improvements thereon which are owned, directly or indirectly, by the Association (the granting of easements for utilities or other purposes and the transfer of Boatslips pursuant to the terms of this Declaration shall not be deemed a transfer within the meaning of this clause);

(b) change the method of determining the obligations, assessments, dues or other charges which may be levied against an Owner;

(c) fail to maintain fire and extended coverage insurance on insurable improvements in the Common Areas on a current replacement cost basis in an amount not less than 100% of the insurable value as set forth in Article 9; or

(d) use the proceeds of any hazard insurance policy covering losses to any part of the Common Areas for other than the repair, replacement or reconstruction of the damaged Common Areas or other common amenities.

Section 10.2. Additional Rights. Any Mortgagee shall have the following rights, to wit:

(a) to be furnished at least one copy of the annual financial statement and report of the Association, such annual statement and report to be furnished within ninety (90) days following the end of each fiscal year;

(b) to be given notice by the Association of the call of any meeting of the Association's membership, and to designate a representative to attend all such meetings;

(c) to be given prompt written notice of default under the Declaration, the Bylaws or any rules and regulations promulgated by the Association by any Owner owning a Lot encumbered by a Mortgage held by the Mortgagee, such notice to be sent to the principal office of such Mortgagee or the place which it may designate in writing;

(d) to be given prompt written notice of any casualty loss to the Common Areas, or loss by eminent domain or other taking of (i) the Common Areas or (ii) any Lot encumbered by a Mortgage held by the Mortgagee;

(e) to be given prompt written notice of any lapse, cancellation or material modification of any insurance policy or fidelity bond maintained by the Association;

(f) to be given prompt written notice of any eminent domain or condemnation proceeding affecting the Property; and

(g) to be given prompt written notice of any action which requires the consent of all or any portion of the Mortgagees as specified herein.

Whenever any Mortgagee desires the provisions of this Section to be applicable to it, it shall serve or cause to be served written notice of such fact upon the Association by certified mail, return receipt requested, addressed to the Association and sent to its address stated herein, identifying the Lot or Lots upon which any such Mortgagee holds any Mortgage or identifying any Lot owned by it, together with sufficient pertinent facts to identify any Mortgage which may be held by it and which notice shall designate the place to which notices are to be given by the Association to such Mortgagee.

Section 10.3. Books and Records. Any Mortgagee will have the right to examine the books and records of the Association during any reasonable business hours.

Section 10.4. Payment of Taxes and Insurance Premiums. The Mortgagees may, jointly or singly, pay taxes or other charges which

are in default and which may or have become a charge or lien against the Common Areas and may pay overdue premiums on hazard insurance policies or secure new hazard insurance coverage upon the lapse of a policy for property owned by the Association and the persons, firms or corporations making such payments shall be owed immediate reimbursement therefor from the Association.

ARTICLE 11

CONDEMNATION

Section 11.1. Partial Taking Without Direct Effect on Lots. If part of the Property shall be taken or condemned by any authority having the power of eminent domain, such that no Lot is taken, all compensation and damages for and on account of the taking of the Common Areas, exclusive of compensation for consequential damages to certain affected Lots, shall be paid to the Board of Directors in trust for all Owners and their Mortgagees according to the loss or damages to their respective interests in such Common Areas; provided, however, that all compensation and damages for and on account of the taking of Piers or Boatslips shall be held in trust for all applicable Owners of Boatlip Lots and their Mortgagees according to the loss or damages to their respective interests in such Piers and Boatslips. The Association, acting through the Board of Directors, shall have the right to act on behalf of the Owners with respect to the negotiation and litigation of the issues with respect to the taking and compensation affecting the Common Areas, without limitation on the right of the Owners to represent their own interests. Each Owner, by his acceptance of a deed to a Lot, hereby appoints the Association as his attorney-in-fact to negotiate, litigate or settle on his behalf all claims arising from the condemnation of the Common Areas. Such proceeds shall be used to restore the Common Areas with the excess, if any, to be retained by the Association and applied to future operating expenses by the Board of Directors, in its sole discretion. Nothing herein is to prevent Owners whose Lots are specifically affected by the taking or condemnation from joining in the condemnation proceedings and petitioning on their own behalf for consequential damages relating to loss of value of the affected Lots, or improvements, fixtures or personal property thereon, exclusive of damages relating to the Common Areas. In the event that the condemnation award does not allocate consequential damages to specific Owners, but by its terms includes an award for reduction in value of Lots without such allocation, the award shall be divided between affected Owners and the Association, as their interests may appear, by the Board of Directors in its sole discretion.

Section 11.2. Partial or Total Taking Directly Affecting Lots. If part or all of the Property shall be taken or condemned by any authority having the power of eminent domain, such that any Lot or a part thereof (including specific easements assigned to any

Lot) is taken, the Association shall have the right to act on behalf of the Owners with respect to Common Area as provided in Section 11.1 and the proceeds shall be payable as outlined therein. The Owners directly affected by such taking shall represent and negotiate for themselves with respect to the damages affecting their respective Lots. All compensation and damages for and on account of the taking of any one or more of the Lots, or improvements, fixtures or personal property thereon, shall be paid to the Owners of the affected Lots and their Mortgagees, as their interests may appear. If all of the Property shall be taken such that the Association no longer has reason to exist and shall thereafter be dissolved and/or liquidated, all compensation and damages for and on account of the taking of the Common Areas shall be distributed with the other assets of the Association in accordance with the Articles of Incorporation.

Section 11.3. Notice to Mortgagees. A notice of any eminent domain or condemnation proceeding shall be sent to all Mortgagees who have served written notice upon the Association in accordance with Section 10.2 hereof.

ARTICLE 12

GENERAL PROVISIONS

Section 12.1. Enforcement. Declarant, being the developer of other subdivisions in the area of the Subdivision, wishes to maintain a high standard in the appearance and quality of the Subdivision. Though damages would be difficult to measure, the failure of the Owners and the Association to abide by the terms, covenants and restrictions contained in this Declaration would result in irreparable damage to Declarant and its reputation. Accordingly, Declarant, during the term of this Declaration as set forth in Section 12.4, as well as the Association or any Owner or Owners, shall have the right, but not the obligation, to enforce all restrictions, conditions, covenants, reservations, liens and charges now or hereafter imposed by the provisions of this Declaration by proceeding at law or in equity against any person or persons violating or attempting to violate any such restriction, covenant, reservation, lien or charge, either to restrain violation thereof or to recover damages therefor. Each Owner and the Declarant shall have all appropriate remedies at law or in equity to enforce the provisions of this Declaration and the Bylaws and any duly authorized rules and regulations governing the Development against the Association.

In addition, the Association hereby covenants and agrees that it shall exercise its power of enforcement hereunder in order to maintain a first class subdivision in appearance and quality, and that it shall, upon the request of Declarant, enforce any restriction, condition, covenant or reservation contained in this Declaration deemed by Declarant, in its sole discretion, to have

been violated, using all remedies available to the Association at law or in equity. The Declarant hereby reserves the right and easement, but not the obligation, to go upon any portion of the Common Areas at any time in order to repair and maintain such Common Areas where needed, in Declarant's sole discretion, to bring such Common Areas within the standards required by Declarant. Should Declarant go upon the Common Areas to perform maintenance and/or repairs for such purpose, the Association hereby agrees to reimburse Declarant in full for the cost of such maintenance and/or repairs, upon receipt of a statement for such cost from Declarant. Declarant shall have the authority, but not the obligation, to exercise the easement rights set forth in this Section 12.1. Failure by Declarant, the Association or by any Owner to enforce any covenant or restriction herein contained shall in no event be deemed a waiver of the right to do so thereafter.

Section 12.2. Severability. Invalidation of any one of these covenants or restrictions by judgment or court order shall in no way affect any other provisions which shall remain in full force and effect.

Section 12.3. Amendment. The covenants and restrictions of this Declaration may be amended at any time and from time to time by an agreement signed by Owners holding a majority of votes appurtenant to the Lots which are then subject to this Declaration; provided, however, that such amendment must be consented to by Declarant so long as Declarant is the Owner of any Lot in the Development. It is further provided that any amendment affecting the Piers and Boatslips and any improvements located thereon must be approved by a vote of no less than two-thirds (2/3) of each class of applicable Owners of Boatslip Lots. Any such amendment shall not become effective until the instrument evidencing such change has been filed of record. Notwithstanding the foregoing, the consent of the Owners holding two-thirds (2/3) of each class of votes in the Association and the approval of Mortgagees holding Mortgages on Lots to which at least two-thirds (2/3) of each class of votes of the Association are appurtenant, plus the written consent of Declarant, shall be required to terminate the legal status of the Association, to withdraw land from the Development, to convey any portion of the Common Areas to any other party, to withdraw any portion of the Property from the requirements of this Declaration, or to restrict or revoke Declarant's right of enforcement hereunder provided for in Section 12.1 of this Declaration. The consent of the Owners having at least two-thirds (2/3) of each class of votes in the Association and the approval of Mortgagees holding Mortgages on Lots to which at least a majority of the votes are appurtenant shall be required to add or amend any material provision of this Declaration which establish, provide for, govern or regulate any of the following:

- (a) voting;
- (b) assessments, assessment liens or subordinations of such liens;
- (c) reserves for maintenance, repair and replacement of the Common Areas;
- (d) insurance or fidelity bonds;
- (e) rights to use of the Common Areas;
- (f) responsibility for maintenance and repair of the Common Areas;
- (g) boundaries of any Lot;
- (h) the interest in the Common Areas;
- (i) convertibility of Lots into Common Areas or of Common Areas into Lots;
- (j) leasing of Lots;
- (k) imposition of any right of first refusal or similar restriction on the right of any Lot Owner to sell, transfer, or otherwise convey his or her Lot; and
- (l) any provisions which are for the express benefit of Mortgagees or insurers or guarantors of Mortgages.

An addition or amendment to the Declaration shall not be considered material if it is for the purpose of correcting technical errors or for clarification only. A Mortgagee who receives a request to approve non-material additions or amendments who does not deliver or post to the requesting party a negative response within thirty (30) days shall be deemed to have approved such request.

Notwithstanding anything in this Section 12.3 to the contrary, Declarant may, at Declarant's option, amend this Declaration without obtaining the consent or approval of any other person or entity if such amendment is necessary to cause this Declaration to comply with the requirements of FHA, VA, the Federal National Mortgage Association or other similar agency.

Section 12.4. Term. The covenants and restrictions of this Declaration are to run with the land (unless otherwise specified herein) and shall be binding upon all parties and all persons claiming under them for a period of twenty-five (25) years from the date this Declaration is recorded; after which time said covenants and restrictions shall be automatically extended for successive

periods of ten (10) years unless an instrument signed by two-thirds (2/3) of the then Owners of the Lots, plus Declarant, has been recorded, agreeing to terminate said covenants and restrictions in whole or in part. Provided, however, that the residential use restrictions set forth in Section 8.1 of this Declaration shall run with the land and shall be binding upon all parties and all persons claiming under them in perpetuity.

Section 12.5. FHA/VA Approval. As long as there is a Class B membership, the following actions will require the prior approval of the Federal Housing Administration or the Veterans Administration: Annexation of Additional Property, dedication of additional Common Areas, and amendment of this Declaration.

IN WITNESS WHEREOF, the Declarant has caused this instrument to be executed by its officers thereunto duly authorized and its corporate seal to be hereunto affixed, all the day and year first above written.

WITNESSES:

CRESCENT RESOURCES, INC.
a South Carolina Corporation

Gina D. Hartwell
First Witness

By: G. L. Ladd
President

Colleen D. Conduro
Second Witness

ATTEST:
Henry L. Roman
Asst. Secretary



FILED FOR RECORD
BOONHEE COUNTY
S.C.
Nov 27 4 23 PM '95
SALLIE O. SMITH
CLERK OF COURT

STATE OF North Carolina

COUNTY OF Mecklenburg

Personally appeared before me, Gina L. Hartsell
(First Witness), and made oath that he/she saw the within named
Crescent Resources, Inc. by Arthur W. Fields
its President and Henry L. Lomax, Jr.
its Asst. Secretary Sign, Seal, and as the Corporate Act and
Deed, deliver the within written Deed; and that he/she with
Coleen D. Girdwood (Second Witness) witnessed the
execution thereof and saw the corporate seal thereto affixed.

Gina L. Hartsell
First Witness

Sworn to before me this 22nd
day of November A.D. 19 95
Coleen D. Girdwood (L.S.)
Notary Public for North Carolina

My Commission Expires 6-19-1999

[SEAL]



FILED FOR RECORD
OCONEE COUNTY
S.C.
Nov 27 4 23 PM 1995
SALLIE O. SMITH
CLERK OF COURT

EXHIBIT "A" TO
DECLARATION
FOR THE SUMMIT
ARTICLES OF INCORPORATION

BOOK 0840 PAGE 0209

STATE OF SOUTH CAROLINA
SECRETARY OF STATE
JIM MILES
NONPROFIT CORPORATION
ARTICLES OF INCORPORATION

THE
LAKE COMPANY
LAKE KEOWEE, SC

1. The name of the nonprofit corporation is THE SUMMIT OWNERS' ASSOCIATION, INC.
2. The initial registered office of the nonprofit corporation is 510 MOUNTAIN VIEW
SENECA, OCONEE COUNTY, SOUTH CAROLINA 29578
Street & Number,
City, County, State, Zip Code

The name of the registered agent of the nonprofit corporation at that office is _____

3. Check (a), (b), or (c) whichever is applicable. Check only one box.
- a. The nonprofit corporation is a public benefit corporation.
- b. The nonprofit corporation is a religious corporation.
- c. The nonprofit corporation is a mutual benefit corporation.

4. Check (a) or (b), whichever is applicable:
- a. This corporation will have members.
- b. This corporation will not have members.

5. The address of the principal office of the nonprofit corporation is 400 SOUTH TRYON STREET
CHARLOTTE, MECKLENBURG, NCRTH CAROLINA 28201-1003
Street & Address,
City, County, State, Zip Code

6. If this nonprofit corporation is either a public benefit or religious corporation (box a. or b. of ¶ 3. is checked), complete either (a) or (b), whichever is applicable, to describe how the remaining assets of the corporation will be distributed upon dissolution of the corporation.

- a. Upon dissolution of the corporation, assets shall be distributed for one or more exempt purposes within the meaning of section 501(c)(3) of the Internal Revenue Code, or the corresponding section of any future federal tax code, or shall be distributed to the federal government, or to a state or local government, for a public purpose. Any such asset not so disposed of shall be disposed of a by the court of common pleas of the county in which the principal office of the corporation is then located, exclusively for such purposes or to such organization or organizations, as said court shall determine, which are organized and operated exclusively for such purposes.
- b. Upon dissolution of the corporation, consistent with law, the remaining assets of the corporation shall be distributed to: _____

7. If the corporation is a mutual benefit corporation (box "c" of ¶ 3. is checked), complete either (a) or (b), whichever is applicable, to describe how the [remaining] assets of the corporation will be distributed upon dissolution of the corporation.

FILED FOR RECORD
OCONEE COUNTY
S.C.
Nov 27 4 23 PM '95
SALLIE O. SHITH
CLERK OF COURT

EXHIBIT "B"
TO
DECLARATION FOR THE SUMMIT

BOOK 0840 PAGE 0210

BYLAWS
OF
THE SUMMIT OWNERS' ASSOCIATION, INC.

ARTICLE 1

NAME AND LOCATION

Section 1.1. Name. The name of the corporation is THE SUMMIT OWNERS' ASSOCIATION, INC., hereinafter referred to as the "Association."

Section 1.2. Location. The principal office of the Association shall be located in either Oconee County, South Carolina. The registered office of the Association may be, but need not be, identical with the principal office.

Section 1.3. Purpose. The purpose for which the Association is organized is to further social activities of Property Owners of Lots in The Summit Subdivision located in Oconee County and in connection therewith to provide services to such property owners, manage and maintain the Common Areas and administer and enforce all covenants and restrictions dealing with the Property located in The Summit and any other purposes allowed by law.

ARTICLE 2

DEFINITIONS

All capitalized terms when used in these Bylaws, or any amendment hereto (unless the context shall otherwise require or unless otherwise specified herein or therein) shall have the meanings set forth in that certain Declaration of Covenants, Conditions and Restrictions for The Summit executed by Crescent Resources, Inc., and duly recorded in the Office of the Clerk of Court for Oconee County, South Carolina, as the same may be supplemented and amended from time to time (the "Declaration").

ARTICLE 3

MEETINGS OF MEMBERS

Section 3.1. Annual Meetings. The first annual meeting of the Members shall be held in May of 1996, or on such other date as determined by a vote of the Board of Directors, and each subsequent regular annual meeting of the Members shall be held in May each year thereafter. If the day for the annual meeting of the Members is a legal holiday, the meeting will be held at the same hour on the first day following which is not a legal holiday.

Section 3.2. Special Meetings. Special meetings of the Members may be called at any time by the President or by the Board of Directors, or upon written request of the Members who are entitled to vote one-fourth ($\frac{1}{4}$) of all of the votes appurtenant to the Lots.

Section 3.3. Meetings of Boatslip Lot Owners. Meetings of the Members owning Boatslip Lots may be called at any time by the President or by the Board of Directors, or upon written request of the Members who are entitled to vote one-fourth ($\frac{1}{4}$) of all of the votes appurtenant to the Boatslip Lots, for the purpose of discussing and voting on matters affecting the Piers and Boatslips. Such meetings may be held at the annual meeting of the Members or at a special meeting of the Members owning Boatslip Lots.

Section 3.4. Place of Meetings. All meetings of the Members and the Members owning Boatslip Lots shall be held at such place, within Mecklenburg County, North Carolina or Oconee County, South Carolina, as shall be determined by the Board of Directors of the Association.

Section 3.5. Notice of Meetings. Written notice of each meeting of the Members and Members owning Boatslip Lots shall be given by, or at the direction of, the Secretary or person authorized to call the meeting, by mailing a copy of such notice, postage prepaid, not less than thirty (30) days nor more than sixty (60) days before the date of such meeting to each Member entitled to vote thereat, addressed to each applicable Member's address last appearing on the books of the Association, or supplied by such Member to the Association for the purpose of notice. Such notice shall specify the place, day and hour of the meeting, and, in the case of a special meeting, the purpose of the meeting.

Section 3.6. Classes of Lots and Voting Rights. The voting rights of the Membership shall be appurtenant to the ownership of Lots. There shall be two classes of Lots with respect to voting rights.

(a) Class A Lots. Class A Lots shall be all Lots except Class B Lots as defined below. Each Class A Lot shall entitle the Owner(s) of said Lot to one (1) vote for each Class A Lot owned. When more than one person owns an interest (other than a leasehold or security interest) in any Lot, all such persons shall be Members and the voting rights appurtenant to said Lot shall be exercised as they, among themselves, determine, but in no event shall more than one (1) vote be cast with respect to any Class A Lot.

(b) Class B Lots. Class B Lots shall be all Lots owned by Declarant which have not been conveyed to purchasers who are not affiliated with the Declarant. Declarant shall be entitled to three (3) votes for each Class B Lot owned by it.

Section 3.7. Relinquishment of Control. The Class B membership shall cease and be converted to Class A membership on the happening of either of the following events, whichever occurs earlier:

(a) when the number of votes in the Class A membership held by Owners occupying full-time homes in the Subdivision equals the total number of votes outstanding in the Class B membership, and the Declarant surrenders its right to annex any Additional Property to the Property pursuant to these Bylaws; or

(b) upon the expiration of five (5) full years after the registration of this Declaration; or

(c) Declarant, in its sole discretion, elects to convert the Class B Lots to Class A Lots. Any such election, to be effective, must be in writing and recorded in the Office of the Clerk of Courts for Oconee County, South Carolina.

Section 3.8. Quorum. The presence at the meeting of Members entitled to cast, or of proxies entitled to cast, one third (1/3) of the votes appurtenant to the Lots (or to the Boatslip Lots, if a meeting of the Members owning Boatslip Lots) shall constitute a quorum for any action except as otherwise provided in the Articles of Incorporation, the Declaration, or these Bylaws. If, however, such quorum shall not be present or represented at any meeting, subsequent meetings may be called, subject to the same notice requirement, until the required quorum is present. No such subsequent meeting shall be held more than sixty (60) days following the preceding meeting.

Section 3.9. Proxies. At all meetings of Members, each Member may vote in person or by proxy. All proxies shall be in writing and filed with the Secretary. Every proxy shall be revocable and shall automatically cease upon conveyance by the Member of his Lot.

Section 3.10. Action by Members. Except as provided otherwise in the Articles of Incorporation, the Declaration or these Bylaws, any act or decision approved by a vote of no less than two-thirds (2/3) of all votes present at a duly held meeting of the Members at which a quorum is present shall be regarded as the act of the Members.

Section 3.11. Action by Members Owning Boatslip Lots. Except as otherwise provided in the Articles of Incorporation, the Declaration or the Bylaws, any act or decision approved by a vote of no less than two-thirds (2/3) of all votes present at a duly

held meeting of the Members owning Boatslip Lots at which a quorum is present shall be regarded as the act of such Members.

Section 3.12. Waiver of Notice. Any Member may, at any time, waive notice of any meeting of the Members or Members owning Boatslip Lots in writing and such waiver shall be deemed equivalent to the giving of such notice. Attendance by a Member at any meeting of the Members or Members owning Boatslip Lots shall constitute a waiver of notice by him of the time and place thereof except where a Member attends a meeting for the express purpose of objecting to the transaction of any business because the meeting was not lawfully called. If all the Members are present at any meeting of the Members, or if all the Members owning Boatslip Lots are present at a meeting of such Members, no notice shall be required and any business may be transacted at such meeting.

Section 3.13. Informal Action by Members. Any action which may be taken at a meeting of the Members or Members owning Boatslip Lots may be taken without a meeting if a consent in writing, setting forth the action so taken, shall be signed by all of the persons who would be entitled to vote upon such action at a meeting and filed with the Secretary of the Association to be kept in the Association's minute book.

ARTICLE 4

BOARD OF DIRECTORS

Section 4.1. Number. The business and affairs of the Association shall be managed by a Board of three directors, who need not be Members of the Association. At the first annual meeting of the Members following relinquishment of Declarant control pursuant to Section 3.7 of the Bylaws, a Board of three directors shall be elected as described in Section 4.5.

Section 4.2. Initial Directors. The initial directors shall be selected by the Declarant. Such initial directors shall serve at the election of the Declarant from the date upon which the Declaration is recorded in the Office of the Clerk of Court for Oconee County until such time as their successors are duly elected and qualified.

The names of the persons who shall serve on the initial Board of Directors from the date upon which the Declaration is recorded in the Office of the Clerk of Court for Oconee County until such time as their successors are duly elected and qualified are as follows:

<u>Name</u>	<u>Address</u>
Susan L. Foster	400 South Tryon Street, Suite 1300 Charlotte, N. C. 28201
Stephen M. Schreiner	400 South Tryon Street, Suite 1300 Charlotte, N. C. 28201
Gilbert D. Stephenson, Jr.	400 South Tryon Street, Suite 1300 Charlotte, N. C. 28201

Section 4.3. Nomination. Nomination for election to the Board of Directors shall be made from the floor at the first meeting of the Members. After the first election of directors, nomination for election to the Board of Directors shall be made by a Nominating Committee. Nominations may also be made from the floor at the annual meeting. The Nominating Committee shall consist of a Chairman, who shall be a member of the Board of Directors, and two or more Members of the Association. The Nominating Committee shall be appointed by the Board of Directors prior to each annual meeting of the Members, to serve from the close of such annual meeting until the close of the next annual meeting and such appointment shall be announced at each annual meeting. The Nominating Committee shall make as many nominations for election to the Board of Directors as it shall in its discretion determine, but not less than the number of vacancies that are to be filled.

Section 4.4. Election. Except as provided in Section 4.6, Directors shall be elected at the annual meeting of the Members by written ballot. At such election, the Members or their proxies may cast, in respect to each vacancy, as many votes as they are entitled to exercise under the provisions of the Declaration. The persons receiving the largest number of votes shall be elected. Cumulative voting is not permitted.

Section 4.5. Term of Office. Each director shall hold office for the term for which he was elected, or until his death, resignation, retirement, removal, disqualification or until his successor is elected and qualified. At the first annual meeting of the Members following the relinquishment of Declarant control as set forth in Section 3.7 of the Bylaws, the Members shall elect one (1) Member of the Board of Directors for a term of three (3) years, who shall be the person receiving the largest number of votes, and one (1) Member of the Board of Directors for a term of two (2) years, who shall be the person receiving the second largest number of votes, and one (1) Member of the Board of Directors for a term of one (1) year, who shall be the person receiving the third

largest number of votes. Following the first annual election after the relinquishment of Declarant control, at all annual elections thereafter, a director shall be elected by the Members to succeed that director whose term then expires. Nothing herein contained shall be construed to prevent the election of a director to succeed himself.

Section 4.6. Removal. Any director may be removed from the Board, with or without cause, by a majority vote of the Members of the Association. In the event of death, resignation or removal of a director, his successor shall be selected by the remaining members of the Board and shall serve for the unexpired term of his predecessor. The Members may elect a director at any time to fill any vacancy not filled by the directors.

Section 4.7. Compensation. No director shall receive compensation for any service he may render to the Association. However, any director may be reimbursed for his actual expenses incurred in the performance of his duties.

ARTICLE 5

MEETINGS OF DIRECTORS

Section 5.1. Regular Meetings. Meetings of the Board of Directors shall be held on a regular basis as often as the Board sees fit, but no less often than annually, on such days and at such place and hour as may be fixed from time to time by resolution of the Board. Should said meeting fall upon a legal holiday, then that meeting shall be held at the same time on the next day which is not a legal holiday.

Section 5.2. Special Meetings. Special Meetings of the Board of Directors shall be held when called by the President of the Association, or by any two directors, after not less than three (3) days notice to each director.

Section 5.3. Quorum. A majority of the number of directors shall constitute a quorum for the transaction of business. Every act or decision done or made by a majority of the directors present at a duly held meeting at which a quorum is present shall be regarded as the act of the Board.

Section 5.4. Informal Action by Directors. Action taken by a majority of the directors without a meeting is nevertheless Board action if written consent to the action in question is signed by all of the directors and filed with the minutes of the proceedings of the Board, whether done before or after the action so taken.

Section 5.5. Chairman. A Chairman of the Board of Directors shall be elected by the directors and shall preside over all Board meetings until the President of the Association is

elected. Thereafter, the President shall serve as Chairman. In the event there is a vacancy in the office of the Presidency, a Chairman shall be elected by the Board of Directors and serve until a new President is elected.

Section 5.6. Liability of the Board. The members of the Board of Directors shall not be liable to the Owners for any mistake of judgment, negligence, or otherwise except for their own individual willful misconduct or bad faith. The Owners shall indemnify and hold harmless each of the members of the Board against all contractual liability to others arising out of contracts made by the Board on behalf of the Association unless any such contract shall have been made in bad faith or contrary to the provisions of the Declaration or these Bylaws. It is intended that the members of the Board of Directors shall have no personal liability with respect to any contract made by them on behalf of the Association, except to the extent that they are Owner(s).

ARTICLE 6

POWERS AND DUTIES OF THE BOARD OF DIRECTORS

Section 6.1. Powers. The Board of Directors shall have power to:

(a) adopt and publish rules and regulations governing the use of the Common Areas and facilities, including but not limited to the Amenity Area, the Street Lights (to be leased from Duke Power Company), Entrance Monuments, Pier, Boatslips, Boat Storage Area, Public Roads (prior to acceptance by a governmental agency), Clubhouse, Pool, Tennis Court, and Parking Area and the personal conduct of the Members and their guests thereon, and to establish penalties for the infraction thereof;

(b) suspend the voting rights and right to use of the recreational facilities of a Member, including the rights to use the Amenity Area, Piers, Boatslips and Boat Storage Area (and all improvements thereon) during any period in which such Member shall be in default in the payment of any assessment levied by the Association. Such rights may also be suspended after notice and hearing, for a period not to exceed sixty (60) days for infraction of published rules and regulations;

(c) exercise for the Association all powers, duties and authority vested in or delegated to this Association and not reserved to the membership by other provisions of these Bylaws, the Articles of Incorporation or the Declaration;

(d) declare the office of a member of the Board of Directors to be vacant in the event such member shall be absent from three (3) consecutive regular meetings of the Board of Directors;

(e) employ a manager, an independent contractor, or such other employees as they deem necessary, and prescribe their duties;

(f) employ attorneys to represent the Association when deemed necessary;

(g) grant easements for the installation and maintenance of sewer or water lines and other utilities or drainage facilities upon, over, under and across the Common Areas without the assent of the membership when such easements are requisite for the convenient use and enjoyment of the Property;

(h) appoint and remove at pleasure all officers, agents and employees of the Association, prescribe their duties, fix their compensation and require of them such security or fidelity bond as it may deem expedient;

(i) do anything necessary or desirable, including, but not limited to, establishing any rules or regulations which the Association deems necessary to carry out the purposes of the Association as set forth herein or as permitted by law;

(j) enforce the provisions of the Declaration and any one or more Amendments or Supplementary Declarations and any rules or regulations made hereunder or thereunder and to enjoin and/or, at its discretion, seek damages or other relief for violation of such provisions or rules and/or by Special Individual Assessments against any Owner for violation of such provisions, rules or regulations pursuant to the provisions of the Declaration; and

(k) to levy assessments as more particularly set forth in the Declaration.

Section 6.2. Duties. It shall be the duty of the Board of Directors to:

(a) cause to be kept a complete record of all its acts and corporate affairs and to present a statement thereof to the Members at the annual meeting of the Members, or at any special meeting when such statement is requested in writing by Members entitled to at least one-third (1/3) of the votes appurtenant to the Lots;

(b) supervise all officers, agents and employees of the Association, and to see that their duties are properly performed;

(c) as more fully provided in the Declaration:

(1) fix the amount of the Annual, Supplemental, Special, Special Individual, Annual Boatslip, Supplemental Boatslip and Special Boatslip Assessments;

Section 7.5. Resignation and Removal. Any officer may be removed from office with or without cause by the Board. Any officer may resign at any time by giving written notice to the Board, the President or the Secretary. Such resignation shall take effect on the date of receipt of such notice or at any later time specified therein, and unless otherwise specified therein, the acceptance of such resignation shall not be necessary to make it effective.

Section 7.6. Vacancies. A vacancy in any office may be filled by appointment by the Board. The officer appointed to such vacancy shall serve for the remainder of the term of the officer he replaces.

Section 7.7. Multiple Offices. The offices of Secretary and Treasurer may be held by the same person. No person shall simultaneously hold more than one of any of the other offices except in the case of special offices created pursuant to Section 7.4.

Section 7.8. Compensation. No officer shall receive any compensation from the Association for acting as such.

Section 7.9. Duties. The duties of the officers are as follows:

President

(a) The President shall be the principal executive officer of the Association, and subject to the control of the Board, shall supervise and control the management of the Association. The President shall preside at all meetings of the Board of Directors; shall see that orders and resolutions of the Board are carried out; shall sign all leases, mortgages, deeds and other written instruments and shall co-sign all checks and promissory notes.

Vice-President

(b) The Vice-President shall act in the place and stead of the President in the event of his absence, inability or refusal to act, and shall exercise and discharge such other duties as may be required of him by the Board.

Secretary

(c) The Secretary shall record the votes and keep the minutes of all meetings and proceedings of the Board and of the Members, shall keep the corporate seal of the Association and affix it on all papers requiring said seal, shall serve notice of meetings of the Board and of the Members, shall keep appropriate current records showing the members of the Association together with their

(2) send written notice of each assessment to every Owner subject thereto before its due date; and

(3) foreclose the lien against any property for which assessments are not paid within thirty (30) days after due date or to bring an action at law against the owner personally obligated to pay the same;

(d) issue, or to cause an appropriate officer to issue, upon demand by any person, a certificate setting forth whether or not any assessment has been paid, (A reasonable charge may be made by the Board for the issuance of these certificates. If a certificate states an assessment has been paid, such certificate shall be conclusive evidence of such payment.);

(e) procure and maintain adequate liability insurance covering the Association and the directors and officers thereof and adequate hazard insurance on the property owned by the Association, and to divide appropriate portions of such related costs between the applicable assessments described in the Declaration;

(f) cause all officers or employees having fiscal responsibilities to be bonded, as it may deem appropriate; and

(g) cause the Common Areas to be maintained, and if damaged, to replace or repair such Common Areas (and any improvements located thereon) as they see fit.

ARTICLE 7

OFFICERS AND THEIR DUTIES

Section 7.1. Officers. The officers of the Association shall be a President and Vice-President, who shall at all times be members of the Board of Directors, a Secretary, and a Treasurer, and such other officers as the Board may elect from time to time by resolution create.

Section 7.2. Election of Officers. The election of officers shall take place at the first meeting of the Board of Directors following each annual meeting of the Members.

Section 7.3. Term. Each officer of the Association shall be elected annually by the Board and each shall hold office for one (1) year or until his death, resignation, retirement, removal, disqualification, or his successor is elected and qualifies.

Section 7.4. Special Appointments. The Board may elect such other officers as the affairs of the Association may require, each of whom shall hold office for such period, have such authority and perform such duties as the Board may, from time to time, determine.

addresses, and shall perform such other duties as required by the Board.

Treasurer

(d) The Treasurer shall receive and deposit in appropriate bank accounts all monies of the Association and shall disburse such funds as directed by resolution of the Board of Directors, shall sign all checks and promissory notes of the Association, shall keep proper books of account, and shall prepare an annual budget and a statement of income and expenditures to be presented to the membership at its regular annual meeting, and deliver a copy of each to the Members.

ARTICLE 8

COMMITTEES

The Association shall appoint a Nominating Committee, as provided in these Bylaws. In addition, the Board of Directors shall appoint other committees as deemed appropriate in carrying out its purpose.

ARTICLE 9

BOOKS AND RECORDS

The books, records and papers of the Association shall at all times, during reasonable business hours, be subject to inspection by any Member. The Declaration, the Articles of Incorporation and the Bylaws of the Association shall be available for inspection by any member at the principal office of the Association, where copies may be purchased at reasonable cost.

ARTICLE 10

ASSESSMENTS

As more fully provided in the Declaration, each Member is obligated to pay to the Association Annual, Supplemental Annual, Special and Special Individual Assessments, and each Owner of a Boatslip Lot is obligated to pay to the Association Boatslip, Supplemental Boatslip, and Special Boatslip Assessments, as defined in the Declaration. Any assessments (including but not limited to Special Individual Assessments) which are not paid when due shall be delinquent. If an assessment is not paid by its due date, as set forth in the Declaration, the assessment shall bear interest from such due date at the rate of eighteen percent (18%) per annum or the highest rate then permitted by law, whichever is less, plus such late charge as may be established by the Board, and the Association may bring an action at law against the Member personally obligated to pay the same. The late charges, costs of

collection and reasonable attorneys' fees related to any such action shall be added to the amount of such assessment, all in accordance with the provisions of the Declaration. No Member may waive or otherwise escape liability for the assessments provided for herein by non-use of the Property.

ARTICLE 11

CORPORATE SEAL

The Association shall have a seal in circular form having within its circumference the words THE SUMMIT OWNERS' ASSOCIATION, INC.

ARTICLE 12

AMENDMENTS

Section 12.1. These Bylaws may be amended, at a regular or special meeting of the Members, by a vote of at least two-thirds (2/3) of all votes present at a duly held meeting of the Members at which a quorum is present in person or by proxy, except that the Federal Housing Administration or the Veterans Administration shall have the right to veto amendments while there is a Class B membership.

Notwithstanding anything in this Section 12.1 to the contrary, the Class B Member may at its option amend these Bylaws without obtaining the consent or approval of any other person or entity if such amendment is necessary to cause these Bylaws to comply with the requirements of the FHA, VA, Federal National Mortgage Association or similar agency.

Section 12.2. In the case of any conflict between the Articles of Incorporation and these Bylaws, the Articles shall control; and in the case of any conflict between the Declaration and these Bylaws, the Declaration shall control.

ARTICLE 13

MISCELLANEOUS

The fiscal year of the Association shall be the calendar year and shall begin on the first (1st) day of January and end on the thirty first (31st) day of December of every year, except that the first fiscal year shall begin on the date of incorporation.

ARTICLE 14

INDEMNIFICATION OF DIRECTORS
AND OFFICERS

The Association shall indemnify any director or officer or former director or officer of the Association or any person who may have served at the request of the Association as a director or officer of another corporation, whether for profit or not for profit, against expenses (including attorneys' fees) or liabilities actually and reasonably incurred by him in connection with the defense of or as a consequence of any threatened, pending or completed action, suit or proceeding (whether civil or criminal) in which he is made a party or was (or is threatened to be made) a party by reason of being or having been such director or officer, except in relation to matters as to which he shall be adjudged in such action, suit or proceeding to be liable for gross negligence or willful misconduct in the performance of a duty.

The indemnification provided herein shall not be deemed exclusive of any other rights to which those indemnified may be entitled under any statute, bylaw, agreement, vote of Members or disinterested directors or otherwise, both as to action in his official capacity and as to action in another capacity while holding such office, and shall continue as to a person who has ceased to be a director, officer, employee or agent and shall inure to the benefit of the heirs, executors and administrators of such a person.

The Association may purchase and maintain insurance on behalf of any person who is or was a director, officer, employee or agent of the Association, or is or was serving at the request of the Association as a director, officer, employee or agent of another corporation, partnership, joint venture, trust or other enterprise against any liability asserted against him and incurred by him in such capacity, or arising out of his status as such, whether or not the Association would have the power to indemnify him against such liability.

The Association's indemnity of any person who is or was a director or officer of the Association, or is or was serving at the request of the Association as a director or officer of the Association, or is or was serving at the request of the Association as a director or officer of another corporation, partnership, joint venture, trust or other enterprise, shall be reduced by any amounts such person may collect as indemnification (i) under any policy of insurance purchased and maintained on his behalf by the Association or (ii) from such other corporation, partnership, joint venture, trust or other enterprise.

Nothing contained in this Article 14, or elsewhere in these Bylaws, shall operate to indemnify any director or officer if such indemnification is for any reason contrary to any applicable State or Federal law.



EXHIBIT "C" TO
DECLARATION FOR THE SUMMIT
PIERS AND BOATSLIPS

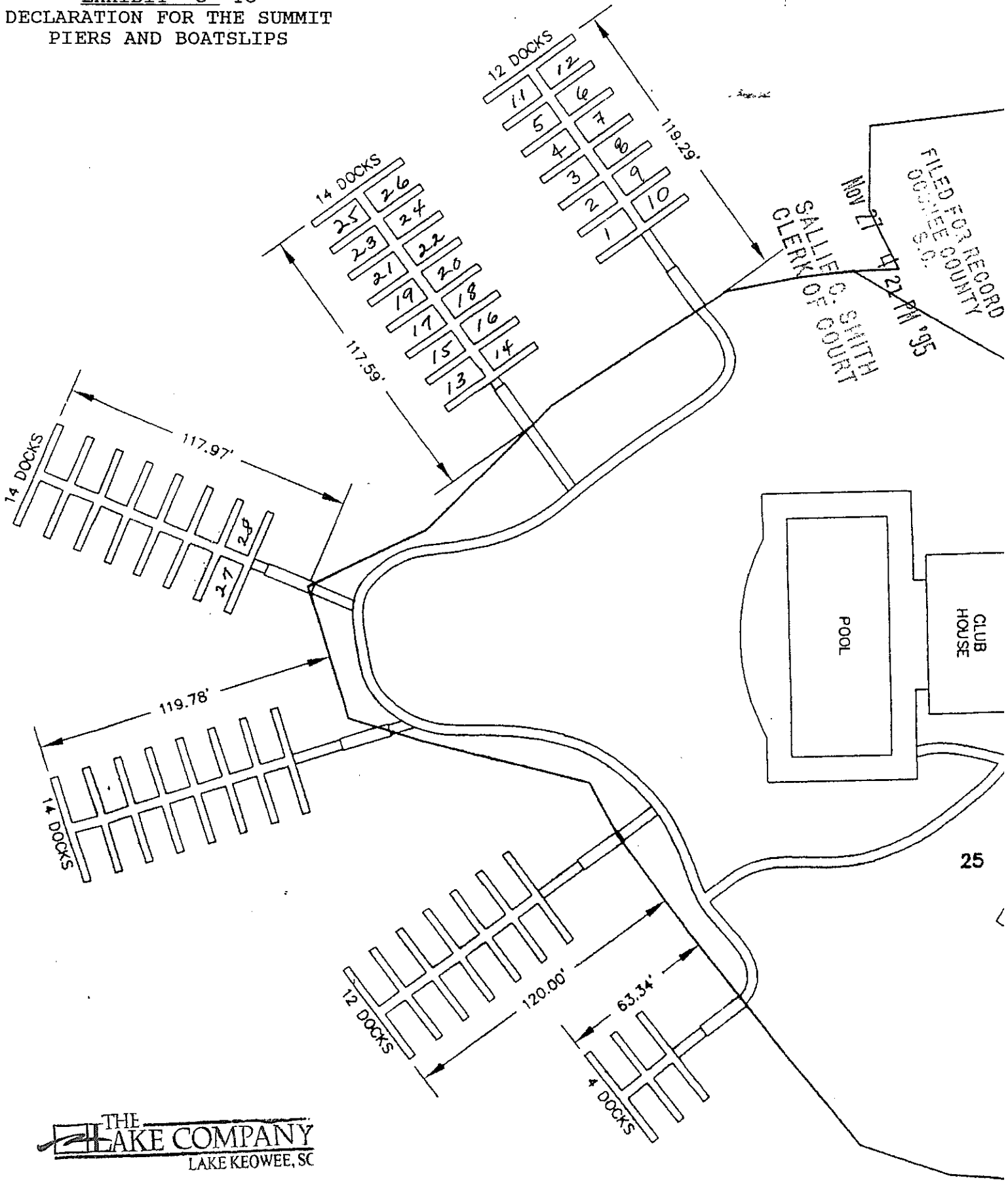

EXHIBIT "D" TO
DECLARATION FOR THE SUMMIT
EROSION CONTROL PRACTICES



Nov 27 4 21 PM '95
SALLIE C. SMITH
CLERK OF COURT
COOHEE COUNTY
FILED FOR RECORD

EXHIBIT "D"
TO DECLARATION FOR THE SUMMIT

EROSION CONTROL
(Page 1 of 4)

Each owner and Approved Builder shall be responsible for causing the following minimum erosion control practices to be implemented and maintained throughout the course of all earth-disturbing operations until the time of final seeding:

a. Roadway and Homesite Construction Entrance

Prior to the start of any earth-disturbing operation, a stone construction entrance shall be installed on the building site (the "Construction Entrance"). The Construction Entrance shall: (i) if possible, be installed in the same location as the proposed driveway so as to minimize the amount of disturbed area; (ii) extend a minimum of 50 feet from an existing roadway; and (iii) be installed, preserved and replaced, if necessary, in accordance with the standards more particularly set forth on page 2 of this Exhibit D.

b. Silt Control Devices

Prior to the start of any earth-disturbing operation, a diversion ditch and rock check dam shall be constructed and maintained on the building site (collectively "Silt Control Devices"). The Silt Control Devices shall be located at the boundary of the estimated disturbed area as set forth more particularly on page 3 of this Exhibit D and shall be constructed, preserved and replaced, if necessary, in accordance with the standards set forth on page 4 of this Exhibit D.

THE
 LAKE COMPANY
LAKE KEOWEE, SC

FILED FOR RECORD
OGOWEE COUNTY
S.C.
Nov 21 4 21 PM '95
SALLIE O. SMITH
CLERK OF COURT

EXHIBIT "D"
FO DECLARATION FOR THE SUMMIT
EROSION CONTROL
(Page 2 of 4)
MINIMUM 10' WIDTH

BOOK 0840 PAGE 0228

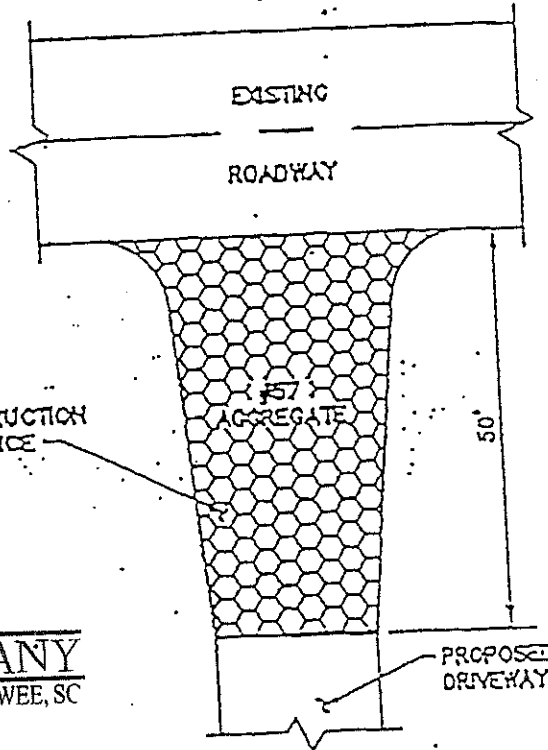
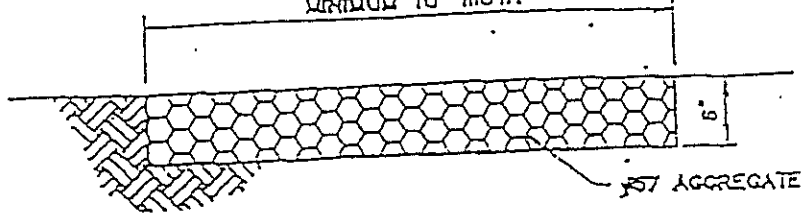

THE
LAKE COMPANY
LAKE KEOWEE, SC

PLAN VIEW

ROADWAY AND HOMESITE
CONSTRUCTION ENTRANCE DETAIL

N. T. S.

FILED FOR RECORD
OCONEE COUNTY
S.C.
Nov 27 4 21 PM '95
SALLIE C. SMITH
CLERK OF COURT

CRESCENT RESOURCES
INC

P.O. BOX 100S
CHARLOTTE, NC 28201

PROJECT

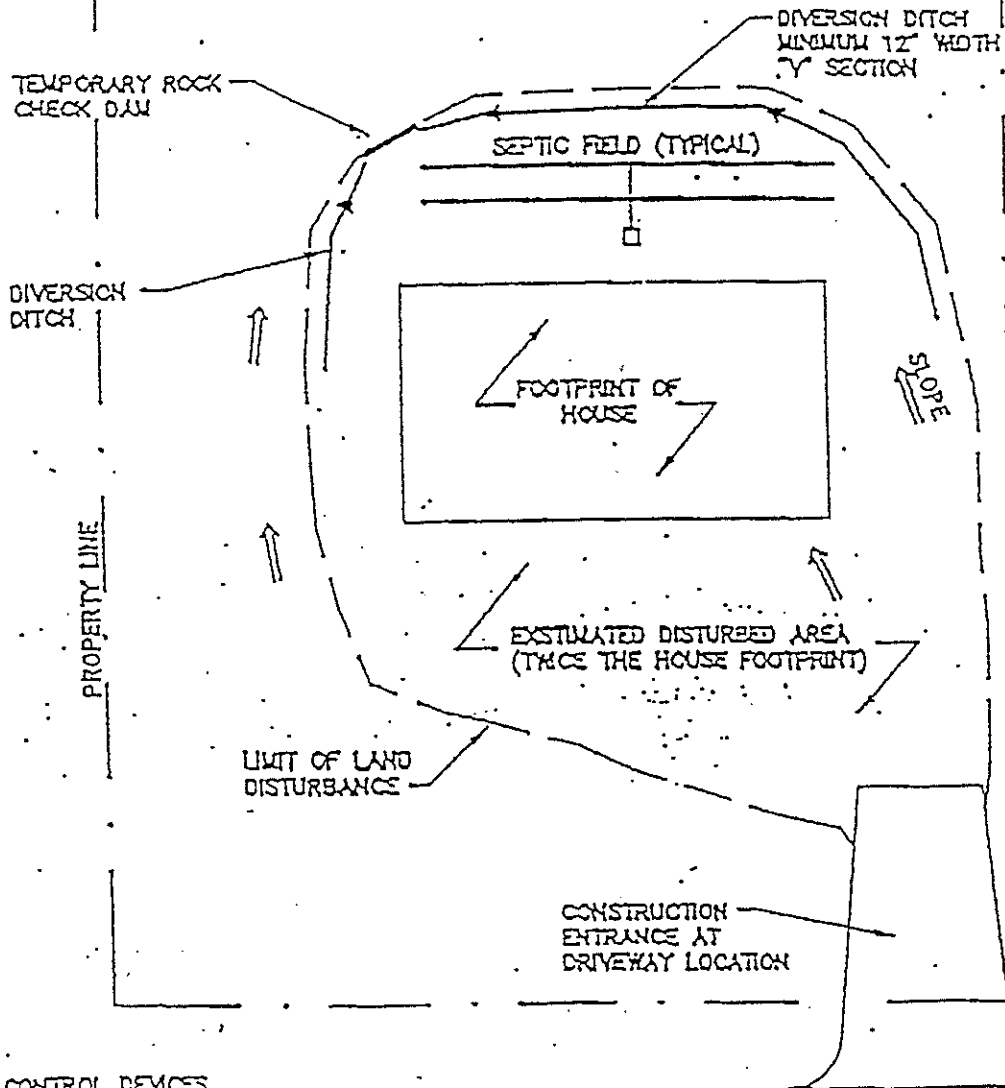

FILED FOR RECORD
COLUMBIA COUNTY
NOV 27 4 21 PM '95
SALLIE C. SMITH
CLERK OF COURT

NOTES:

1. SILT CONTROL DEVICES TO REMAIN IN PLACE UP TO TIME OF FINAL SEEDING.
2. ON WATERFRONT LOTS, ALL SEDIMENT CONTROL DEVICES ARE NOT TO ENCROACH ON 50 FT WATERFRONT SETBACK.

TYPICAL EROSION CONTROL MEASURES
FOR INDIVIDUAL HOMESITES

N. T. S.

CRESCENT RESOURCES
INC

P.O. BOX 1003
CHARLOTTE, NC 28201

PROJECT

THE
LAKE COMPANY
LAKE KEOWEE, SC

EXHIBIT "D"
TO DECLARATION FOR THE SUMMIT
EROSION CONTROL
(Page 4 of 4)

BOOK 0840 PAGE 0230

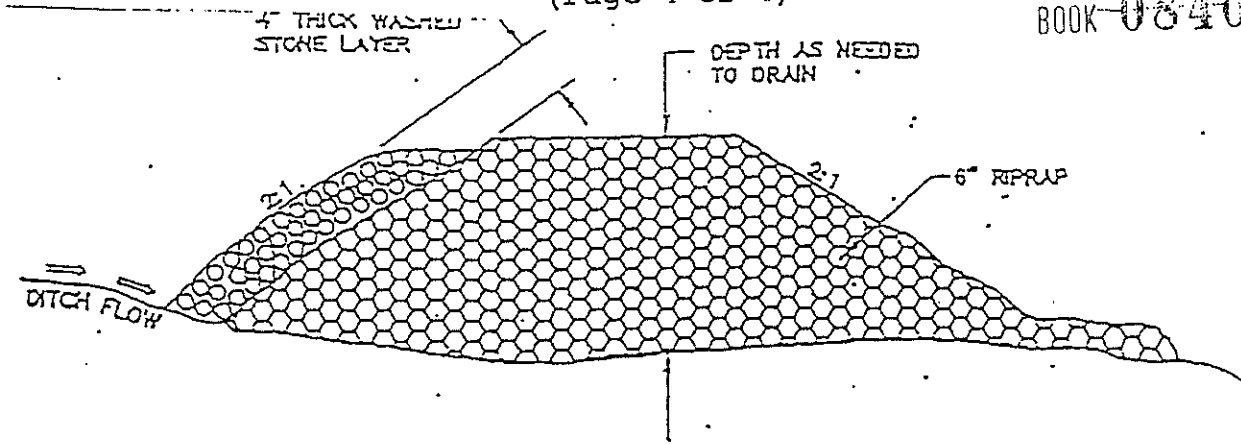

SECTION A-A
N. T. S.

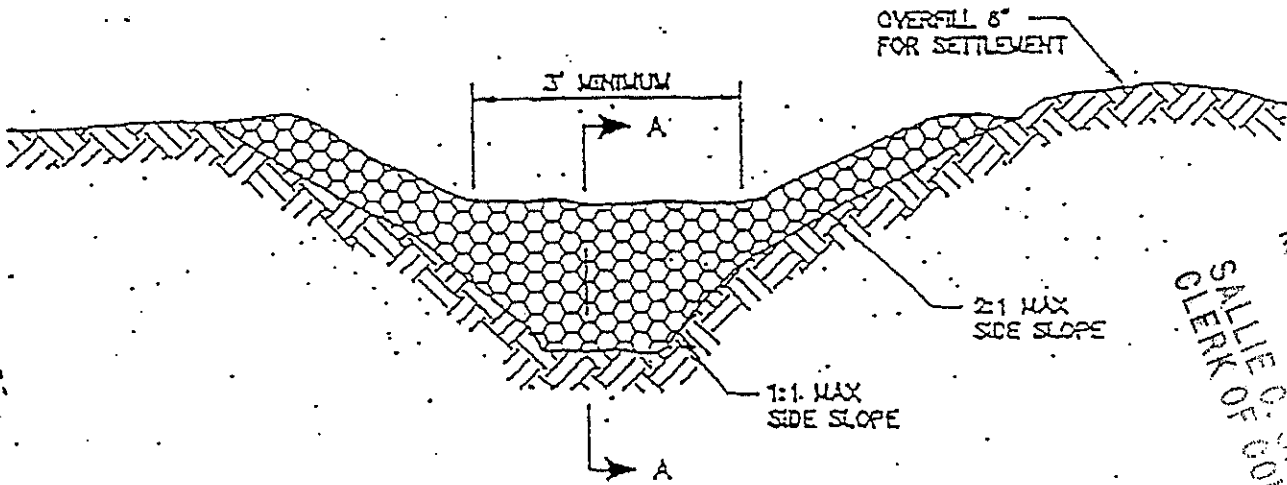

DITCH SECTION
N. T. S.

ROCK CHECK DAM

Nov 21 11 21 AM '95
SALLIE C. SMITH
CLERK OF COURT
COOHEE COUNTY
FILED FOR RECORD

CRESCENT RESOURCES
INC

P.O. BOX 1003
CHARLOTTE, NC 28201

PROJECT

THE
LAKE COMPANY
LAKE KEOWEE, SC

EXHIBIT "E" TO
DECLARATION FOR THE SUMMIT
STANDARD COMMUNITY MAILBOXES



FILED FOR
OCHIEE COU.
S.C.
Nov 21 4 21 PM '95
SALLIE C. SMITH
CLERK OF COURT

FRONT VIEW

SIDE VIEW

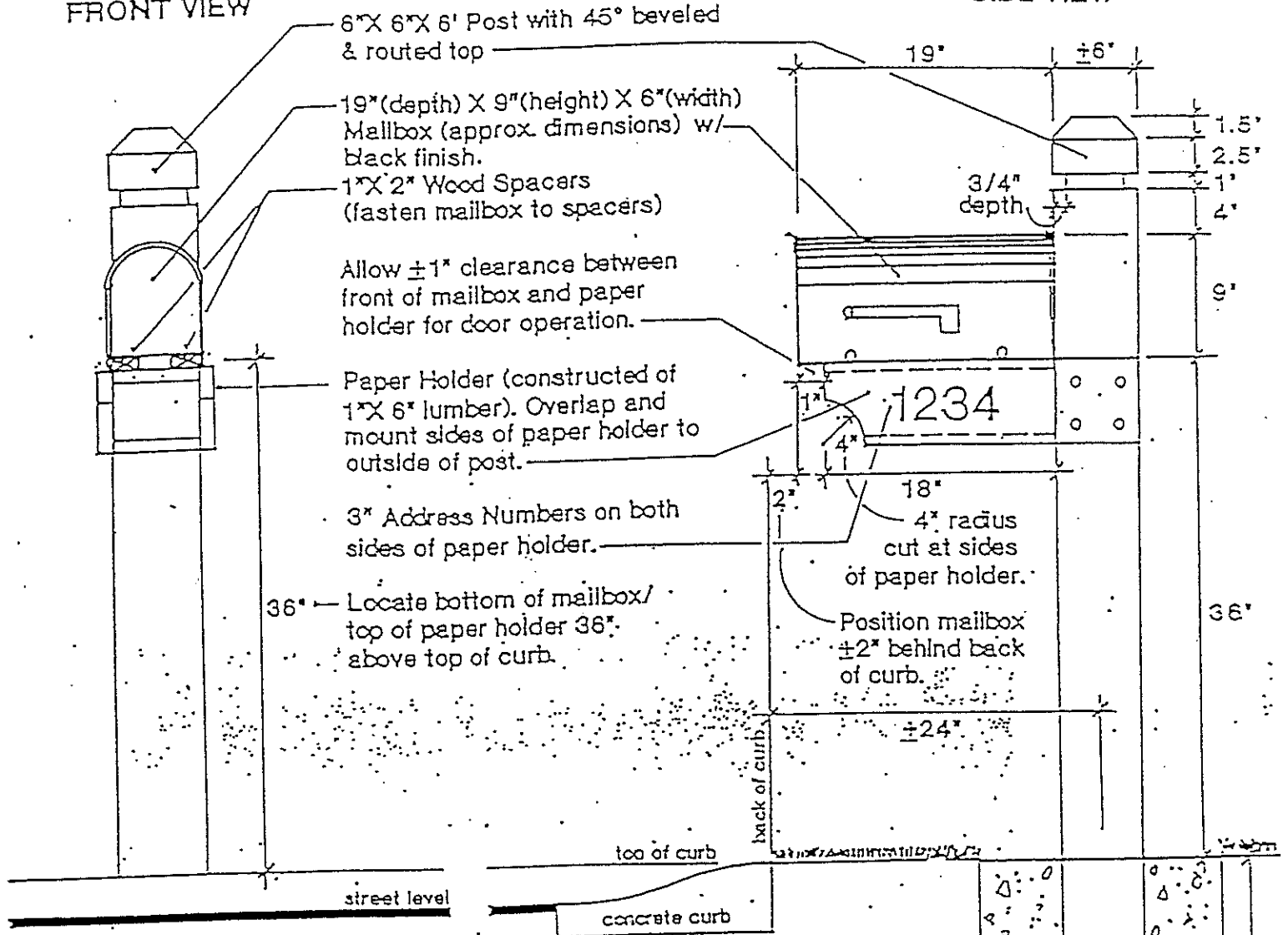

INSTALLATION INSTRUCTIONS

CAUTION: Prior to mailbox installation, it is recommended to locate all underground utilities in the vicinity.

1. Dimension post location from back of curb, generally 24" to center of post. (This dimension is based upon a mailbox depth of 18" - 19"). Dig a 14" - 18" diameter hole to a depth of 18" minimum. Insert post at indicated height, center post in hole, plumb (straighten) and brace secure with timber stakes driven at an angle into ground surrounding hole. Fill hole with concrete (bagged premix will work) and level out flush with surrounding grade.

NOTE: All lumber shall be pressure treated. Apply clear sealer to all exposed surfaces after installation. A 4" x 4" post is not acceptable.

2. Assemble paper holder using 1" x 6"s (cut as shown) and 1" deck screws. Apply clear sealer to the interior surfaces of the paper holder prior to assembly. Install 1" x 2" spacers on top of paper holder with 1" screws.

NOTE: The spacers are recommended as a means of mounting the mailbox to the paper holder and should be installed to match the "lip" and screw holes at the bottom (sides) of the mailbox. Variations in mailbox types and methods of attachment may affect the height, location, and perhaps requirement of spacers.

3. Once the concrete has set (24 hours minimum), slide the assemble paper holder onto the sides of the post at the proper height and secure with (4) 2" deck screws at each side. Apply clear sealer to the area of the post covered by the paper holder prior to installation. Remove the post braces.

4. Mount the mailbox to the paper holder (spacers) with 1" screws at each side. Provide adequate clearance between the front of the mailbox and paper holder to allow for the door operation.

5. Apply clear sealer to remainder of post and paper holder. Mailbox to have (factory) black finish.

6. Install 3" address numbers (black) to both sides of paper holder.

THE LAKE COMPANY
LAKE KEOWEE, SC

EXHIBIT "F" TO
DECLARATION FOR THE SUMMIT
PIER ZONES



FILED FOR RE
CORNER COUNT
S.C.
Nov 27 4 21 PM '95
SALLIE C. SMITH
CLERK OF COURT

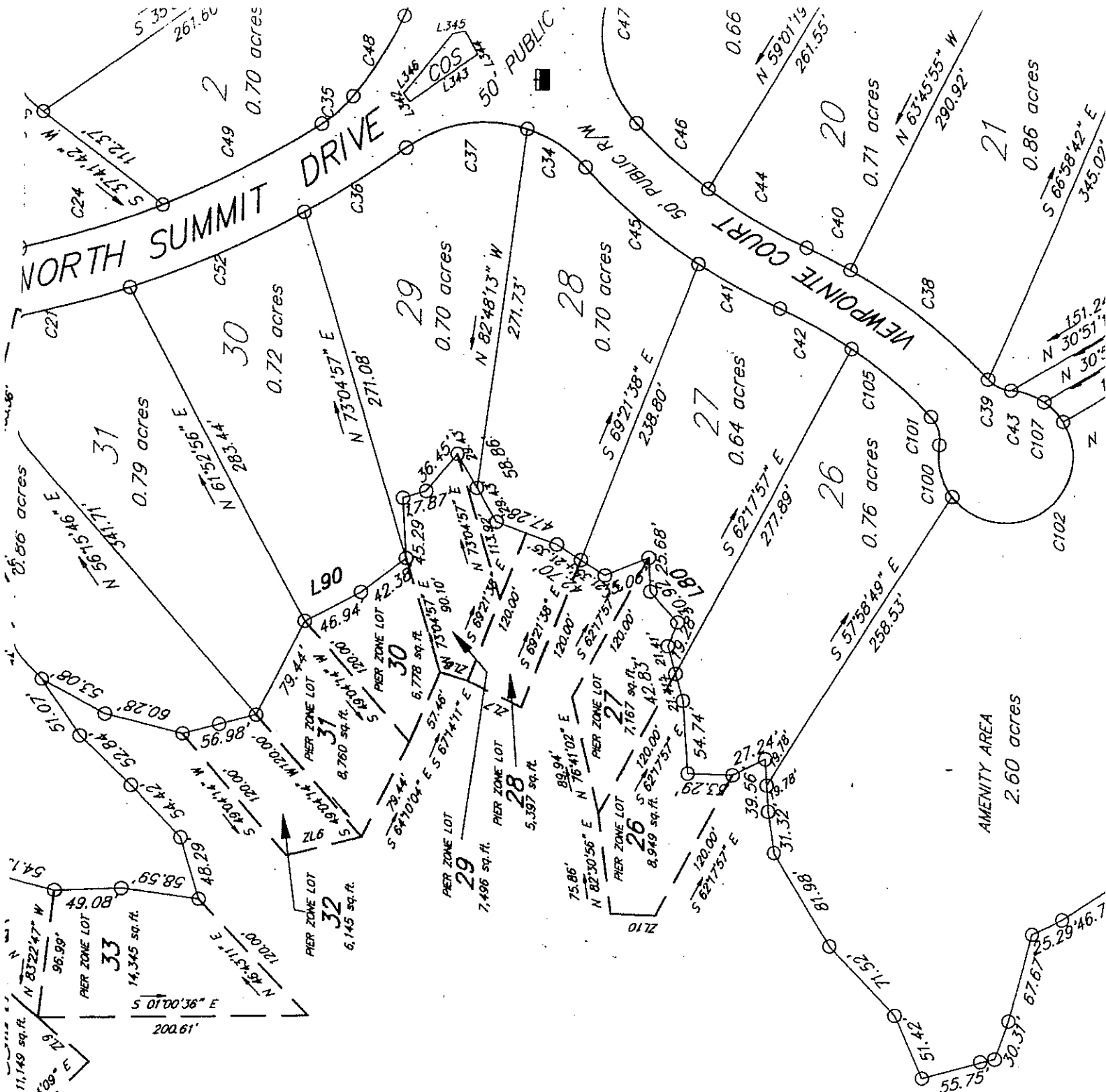

ABOVE 804 MSL CONTOUR.
MSL CONTOUR.

0840 PAGE 02

052.05
K817, K719, K240, K777-B

THE
LAKE COMPANY
LAKE KEOWEE, SC

EXHIBIT "F" TO
DECLARATION FOR THE SUMMIT
PIER ZONES
(Page 1 of 7)

CES, INC.

EXHIBIT "F" TO
 DECLARATION FOR THE SUMMIT
 PIER ZONES
 (Page 2 of 7)

BOOK 0840 PAGE 0235

FILED FOR RECORD
 OCONEE COUNTY
 S.C.

NOV 21 4 21 PM '95
 SALLIE O. SMITH
 CLERK OF COURT

THE
LAKE COMPANY
 LAKE KEOWEE, SC

LAKE KEOWEE

SHORE LINE BOUNDARY FALLS ON OR ABOVE 804 MSL CONTOUR.
 POSSIBLE FLOOD EASEMENT TO 810 MSL CONTOUR.

DESCRIPTION: P/O TMP 209-00-02-052,053.
 DUKE REFERENCE: K431, K992, K270, K817, K719, K240, K777-B
 REFERENCE PLAT BOOK PAGE RECORDS OF OCONEE COUNTY.
 LOCATION: STATE OF SOUTH CAROLINA
 COUNTY OF OCONEE

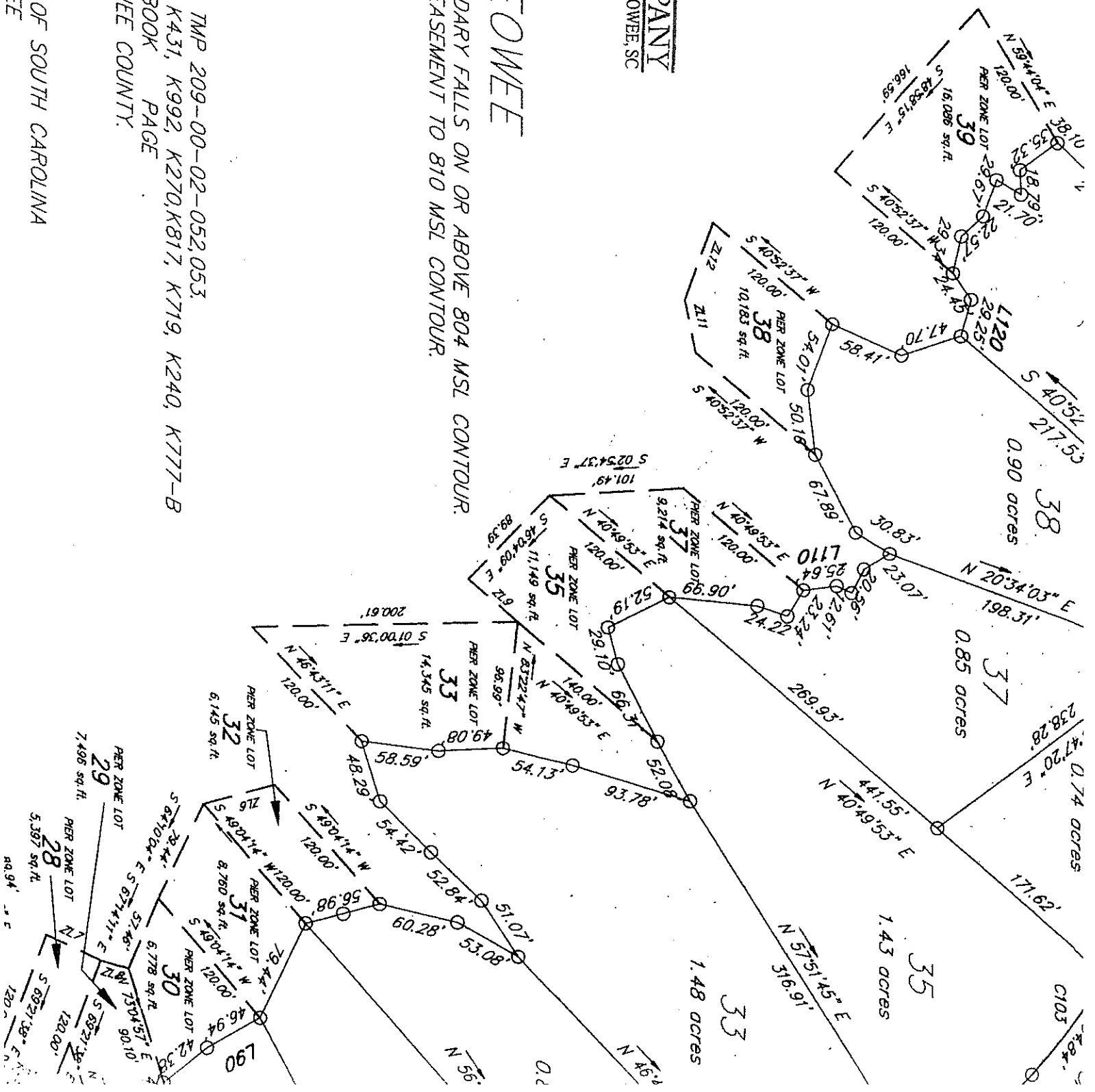

EXHIBIT "F" TO
DECLARATION FOR THE SUMMIT

PIER ZONES

(Page 3 of 7)

BOOK 0840 PAGE 0236

FILED FOR RECORD
BOONE COUNTY
S.C.

Nov 27 4 21 PM '95

SALLIE C. SMITH
CLERK OF COURT

THE LAKE COMPANY
LAKE KEOWEE, SC

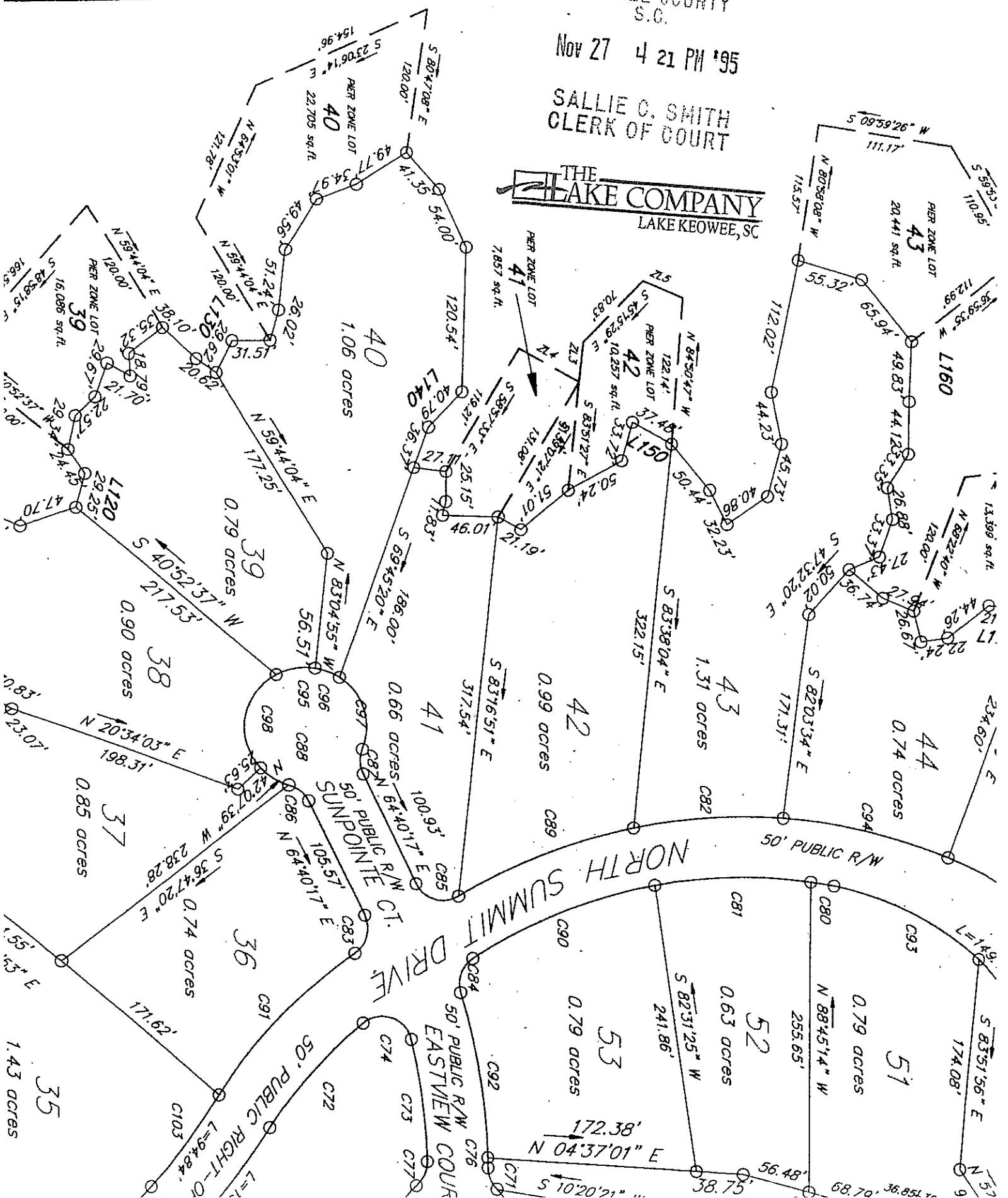

**EXHIBIT "F" TO
DECLARATION FOR THE SUMMITBOOK 0840 PAGE 0237
PIER ZONES
(Page 4 of 7)**

THE LAKE COMPANY
LAKE KEOWEE, SC

NOTE: DASHED LINES WITHIN LAKE KEOWEE REPRESENT PIER ZONES AND R/W'S. EASEMENT TO 810 MSL CONTOUR. SHORE LINE POSSIBLE

LAKE KEOWEE

FILED FOR RECORD
LAKE KEOWEE S.C.
A 21 PM '95

LINE	DIRECTION	DISTANCE
Z11	N 79°05'57" E	45.00'
Z13	S 83°01'16" E	33.00'
Z14	S 30°41'17" W	56.13'
Z15	S 24°11'52" W	36.12'
Z16	S 14°55'16" E	56.98'
Z17	N 28°06'53" E	44.74'
Z18	N 17°07'42" E	21.80'
Z19	S 40°49'53" W	50.00'
Z10	N 01°40'44" E	31.89'
Z11	N 79°05'57" E	41.58'
Z12	S 70°40'04" E	63.22'

PIER ZONE BEARING TABLE ONLY

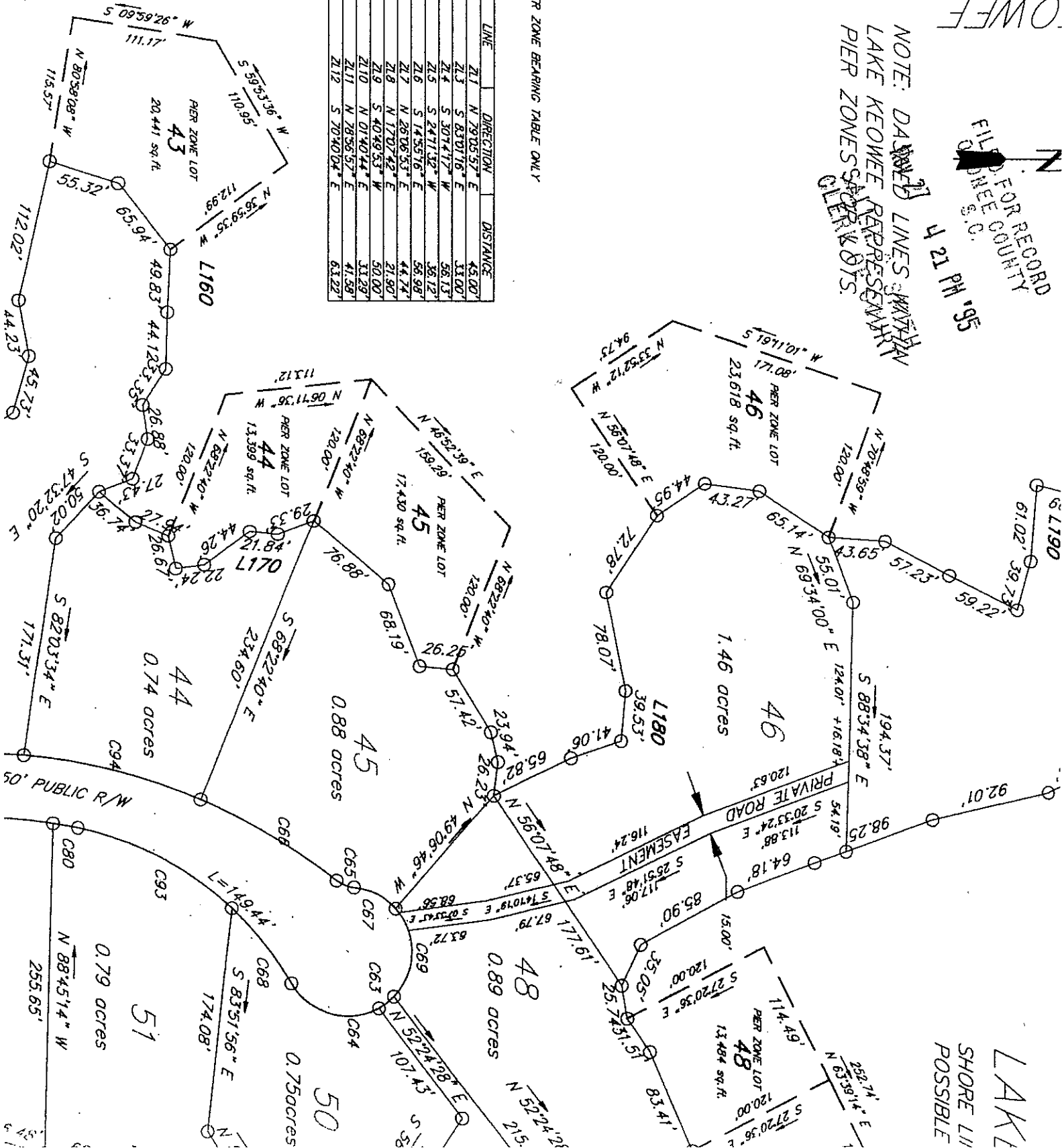

LAKE
SHORE LINE
POSSIBLE

EXHIBIT "F" TO
 DECLARATION FOR THE SUMMIT
 PIER ZONES
 (Page 5 of 7)

THE
 SH
 LAKE
 SHORE LI
 POSSIBLE

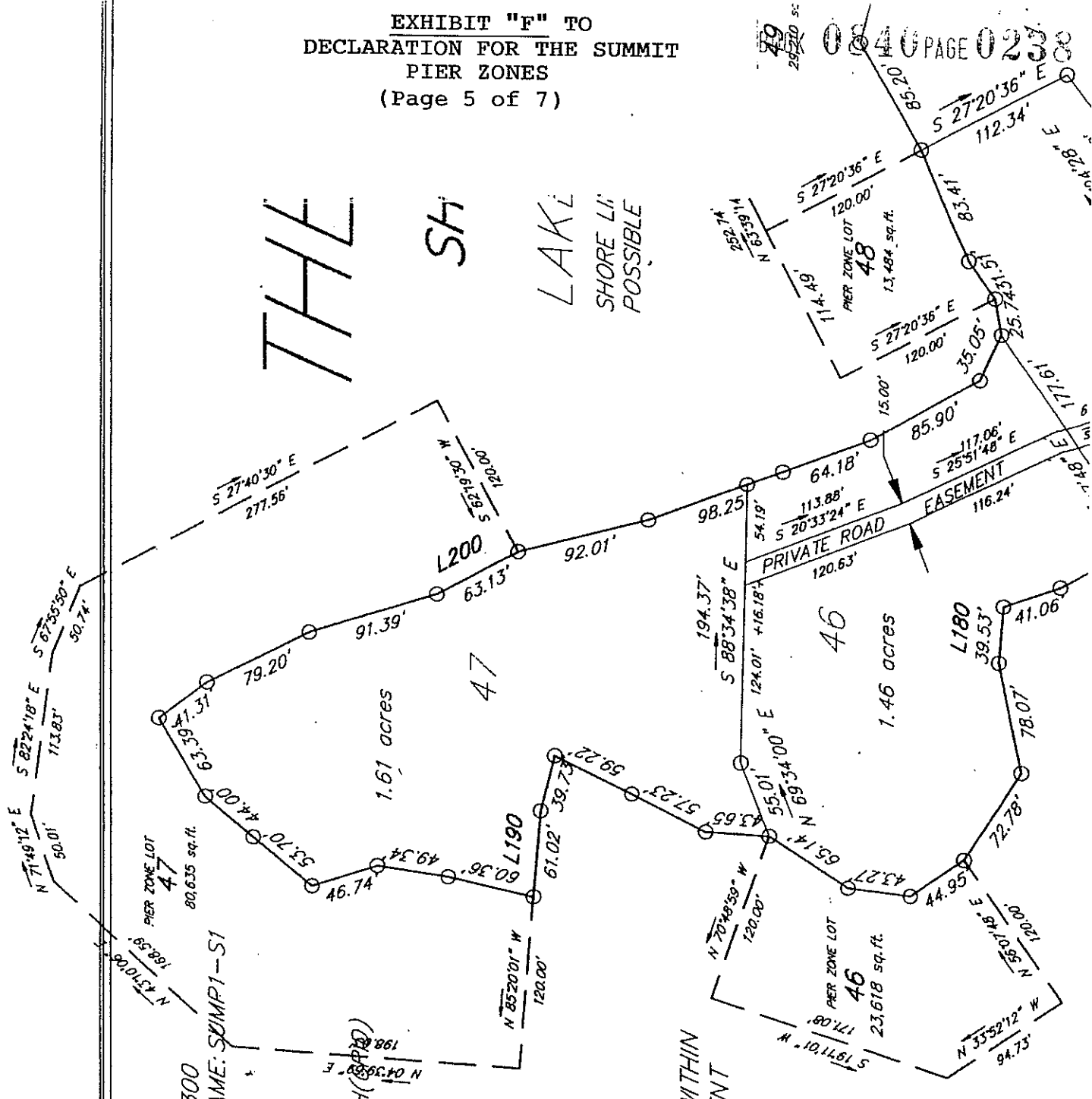

PLAT # B-4179-D-300
 DISK # C: \DWG13 NAME: SUMP1-S1
 FB #100 PG 1-5

REFERENCE PLAT NORTH (8110)



NOTE: DASHED LINES WITHIN
 LAKE KEOWEE REPRESENT
 PIER ZONES FOR LOTS.

THE
 LAKE COMPANY
 LAKE KEOWEE, SC

LAKE KEOWEE

SHORE LINE BOUNDARY FALLS ON OR ABOVE 804 MSL CONTOUR.
 POSSIBLE FLOOD EASEMENT TO 810 MSL CONTOUR.

DECLARATION FOR THE SUMMIT

PIER ZONES
(Page 6 of 7)

L22	N 22°17'45" E	37.09'
L23	N 12°00'31" E	37.18'
L24	N 21°40'16" E	36.09'
L25	N 81°36'08" E	36.31'
L26	N 74°10'06" E	21.99'
L27	N 34°43'39" E	57.07'
L28	N 04°09'18" W	22.52'
L29	N 80°23'32" E	63.36'
L30	N 76°12'27" E	61.05'
L31	N 65°39'09" E	60.46'
L32	N 64°24'49" E	58.94'
L33	N 82°00'15" E	32.23'
L34	S 81°37'20" E	53.94'
L35	S 55°48'50" E	34.20'
L36	N 43°21'01" E	29.68'
L37	N 79°29'11" E	43.16'
L38	S 57°12'04" E	43.33'
L39	S 40°34'01" E	
L40	S 52°33'06" E	
L41	S 44°04'18" E	
L42	S 78°08'12" E	
L43	S 63°53'36" E	
L44	S 58°05'32" E	
L45	S 62°49'50" E	
L46	S 75°17'50" E	
L47	S 69°20'21" E	
L48	N 36°56'50" W	
L49	N 36°32'30" W	
L50	N 64°04'01" E	
L51	N 63°17'51" E	
L52	S 80°00'05" W	
L53	S 77°22'15" W	
L54	S 76°18'18" W	
L55	N 77°53'44" W	
L56	N 44°53'02" W	
L57	N 65°15'39" W	
L58	N 00°03'45" W	
L59	S 65°00'47" W	
L60	N 47°54'57" W	
L61	N 84°42'59" W	
L62	N 71°12'37" W	
L63	N 38°24'18" W	
L64	N 36°56'44" W	
L65	N 34°02'20" W	
L66	N 28°27'54" W	
L67	N 75°23'39" W	
L68	N 70°57'20" W	
L69	N 15°39'35" W	
L70	N 65°51'26" E	51.42'
L71	N 46°17'24" E	71.52'
L72	N 56°37'59" E	81.98'
L73	N 80°58'37" E	31.32'
L74	N 86°00'44" E	39.56'
L75	N 26°32'28" W	27.24'
L76	N 01°49'24" E	33.29'
L77	N 80°59'33" E	54.74'
L78	N 74°27'25" E	42.83'
L79	S 69°02'12" E	19.28'
L80	N 48°44'56" E	30.92'

L180	N 22°17'45" E	37.09'
L181	N 12°00'31" E	37.18'
L182	N 21°40'16" E	36.09'
L183	N 81°36'08" E	36.31'
L184	N 74°10'06" E	21.99'
L185	N 34°43'39" E	57.07'
L186	N 04°09'18" W	22.52'
L187	N 80°23'32" E	63.36'
L188	N 76°12'27" E	61.05'
L189	N 65°39'09" E	60.46'
L190	N 64°24'49" E	58.94'
L191	N 82°00'15" E	32.23'
L192	S 81°37'20" E	53.94'
L193	S 55°48'50" E	34.20'
L194	N 43°21'01" E	29.68'
L195	N 79°29'11" E	43.16'
L196	S 57°12'04" E	43.33'
L197	S 40°34'01" E	
L198	S 52°33'06" E	
L199	S 44°04'18" E	
L200	S 78°08'12" E	
L201	S 63°53'36" E	
L202	S 58°05'32" E	
L203	S 62°49'50" E	
L204	S 75°17'50" E	
L205	S 69°20'21" E	
L206	N 36°56'50" W	
L207	N 36°32'30" W	
L208	N 64°04'01" E	
L209	N 63°17'51" E	
L210	S 80°00'05" W	
L211	S 77°22'15" W	
L212	S 76°18'18" W	
L213	N 77°53'44" W	
L214	N 44°53'02" W	
L215	N 65°15'39" W	
L216	N 00°03'45" W	
L217	S 65°00'47" W	
L218	N 47°54'57" W	
L219	N 84°42'59" W	
L220	N 71°12'37" W	
L221	N 38°24'18" W	
L222	N 36°56'44" W	
L223	N 34°02'20" W	
L224	N 28°27'54" W	
L225	N 75°23'39" W	
L226	N 70°57'20" W	
L227	N 15°39'35" W	
L228	N 65°51'26" E	51.42'
L229	N 46°17'24" E	71.52'
L230	N 56°37'59" E	81.98'
L231	N 80°58'37" E	31.32'
L232	N 86°00'44" E	39.56'
L233	N 26°32'28" W	27.24'
L234	N 01°49'24" E	33.29'
L235	N 80°59'33" E	54.74'
L236	N 74°27'25" E	42.83'
L237	S 69°02'12" E	19.28'
L238	N 48°44'56" E	30.92'

THE
LAKE COMPANY
LAKE KEOWEE, SC

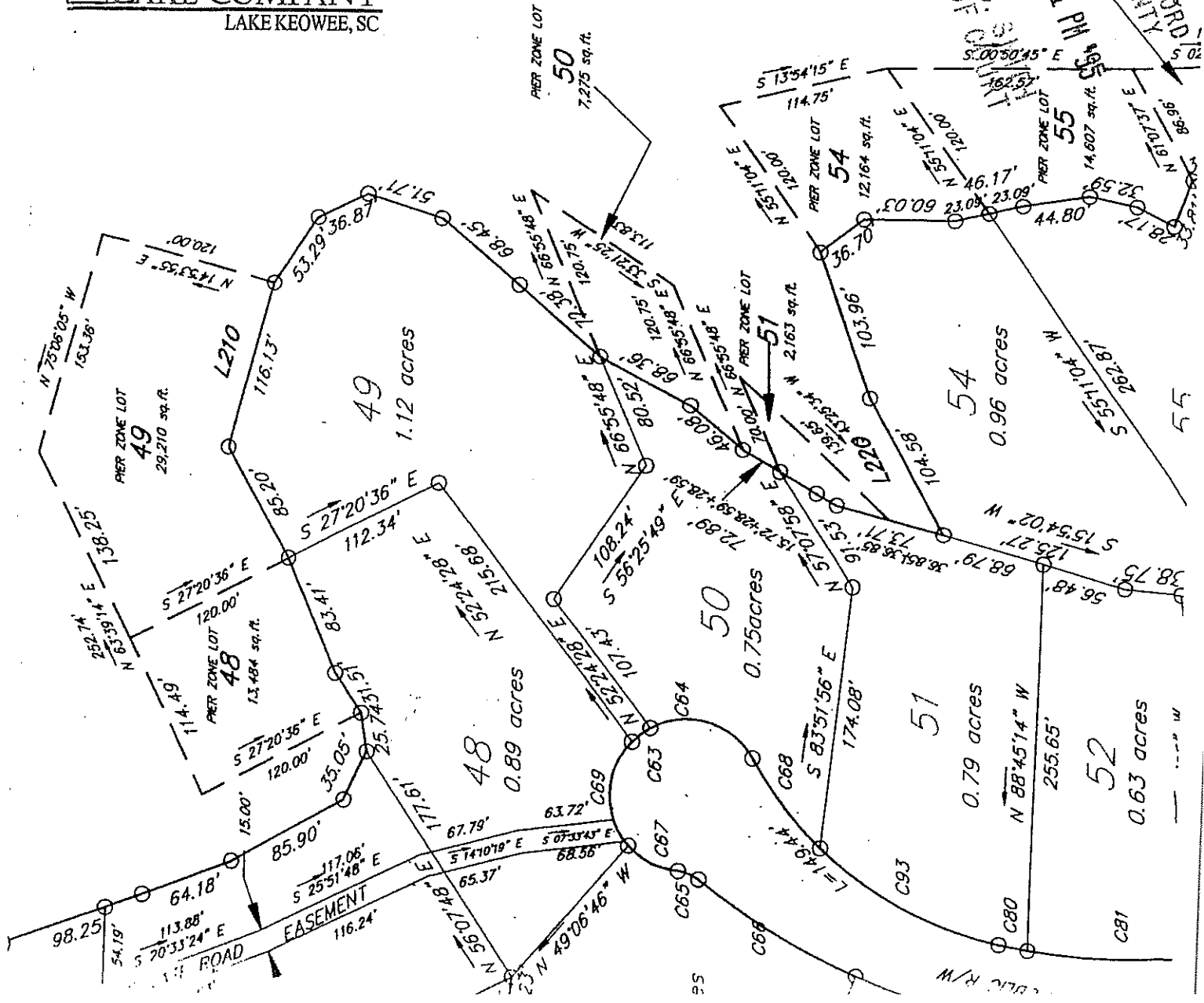
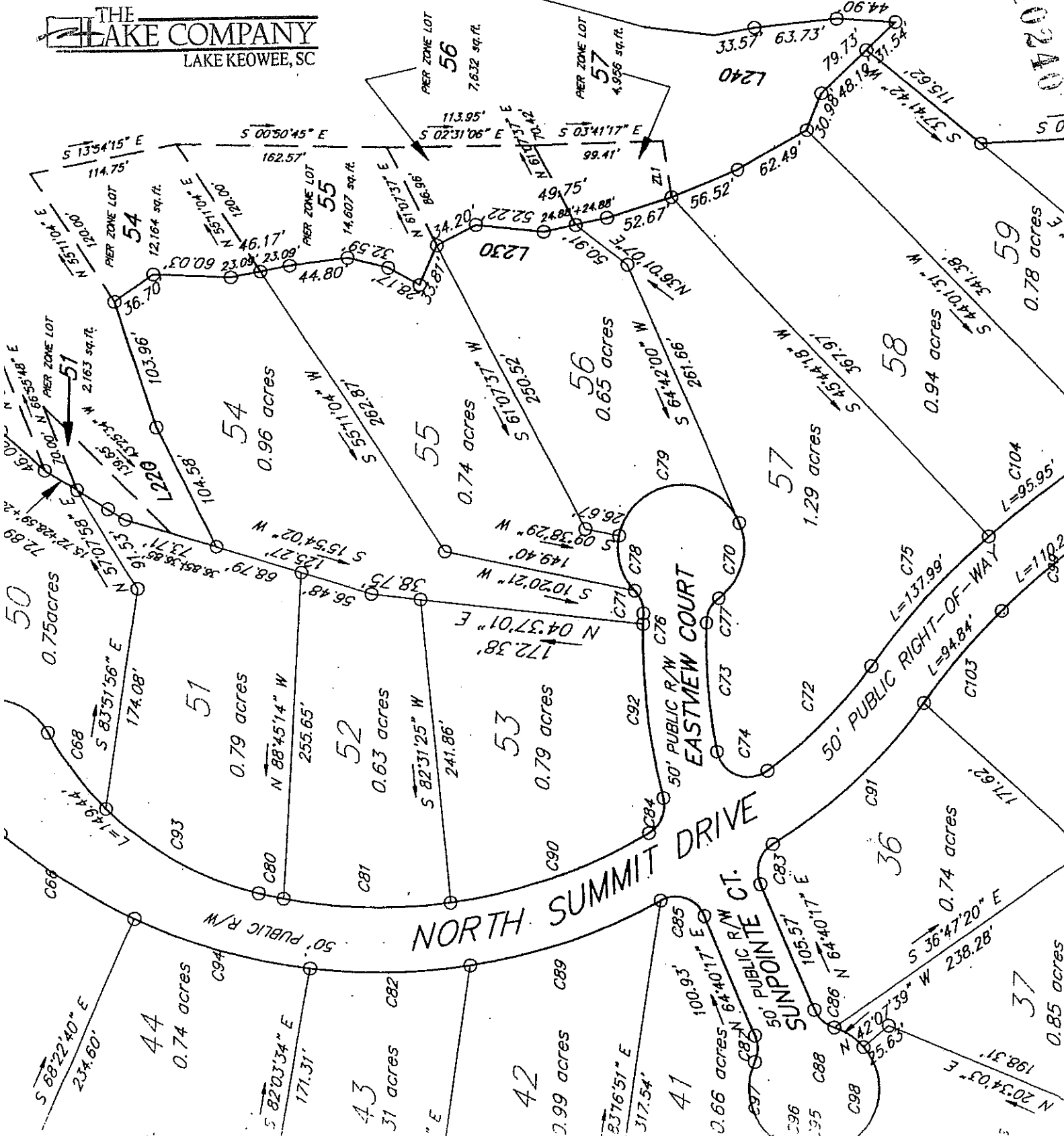

**EXHIBIT "F" TO
DECLARATION FOR THE SUMMIT
PIER ZONES
(Page 7 of 7)**

L55	N 77°53'44" W
L56	N 44°53'02" W
L57	N 63°15'39" W
L58	N 00°03'45" W
L59	S 65°00'47" W
L60	N 47°54'57" W
L61	N 84°42'59" W
L62	N 71°12'37" W
L63	N 38°24'18" W
L64	N 36°56'44" W
L65	N 34°02'20" W
L66	N 26°27'54" W
L67	N 75°23'39" W
L68	N 70°57'20" W
L69	N 15°39'35" W
L70	N 65°51'26" W

L102	N 177°02'3" E
L103	S 61°20'42" W
L104	S 62°41'40" W
L105	S 75°21'56" W
L106	N 26°13'34" W
L107	N 05°52'22" E
L108	N 19°08'53" E
L109	N 59°07'07" W
L110	N 07°13'07" W

THE LAKE COMPANY
LAKE KEOWEE, SC



BOOK 0840 PAGE 0240

37 0.85 acres